

Overview

5504-DK is a high quality stand-alone development board based on SAM5504B (AUDIO & MUSIC MULTI-DSP PROCESSOR).

The SAM5504B can be used in 2 different hardware configurations for different applications. On 5504-DK board the SAM5504B is running in the hardware configuration dedicated to sound module or keyboard instruments built around low cost Quad SPI memory components.

Samples are stored in Quad SPI Flash and read from it in Quad I/O Read Mode (100MHz) through the SAM5504B Sample Cache Controller to reach 81-voice polyphony.

Thanks to the secondary functions implemented beside primary functions of numerous pins, 5504-DK also offers plenty of audio I2S IOs, SPDIF IO and USB audio.

Beside the SAM5504B, the 5504-DK_Rev1 hardware includes:

- 2 Audio DAC: AKM AK4384(24-bit, DR:106dB, THD+N:-94dB)
- 1 Audio ADC AKM AK5386 (24-bit, DR:110dB, S/(N+D):96dB)
- 512Mbit Quad SPI Flash Memory: SPANSION S25FL512SAGMFI01
- USB High Speed, Device port
- Optical SPDIF In and Out

Operating Mode

5504-DK operates on two modes:

- **Debug mode:**

The board is connected to a PC through the Dream 5000DBG-IF adaptor. The firmware can be downloaded and debugged into Quad SPI Flash memory with Dream SamVS-C development software. With SamVS or ProgSam software tool it is possible to program the firmware in Quad SPI Flash memory for stand-alone mode. With ProgSam tool it is also possible to program the eFuses in SAM5504B for encryption / copy protection of firmware code and sound bank content.

The sound bank can also be loaded into Quad SPI Flash memory using UXChange.exe software or copying it directly from USB drive plugged through 5000USBH-IF adapter.
- **Stand-alone mode:**

In this mode the SAM5504B executes the program from the Quad SPI Flash memory playing MIDI events from USB Midi and optionally scans the front panel and the piano keyboard.

Connectors Configuration

Name	Reference	Type	Description
DEBUG / PROGRAM	J1	JST PH Series, 1*5	Serial connection for debug and program, compatible with Dream 5000DBG-IF
MIDI OUT	J2	5-pin Din	Standard MIDI OUT at 31.25kb/s
MIDI IN	J3	5-pin Din	Standard MIDI IN at 31.25kb/s
MIDI LVTTTL	J4	1*3	MIDI LVTTTL IO at 31.25kb/s
EXTENSIONS	J5	HE10, 2*17	Audio extension or Scanning interface or Versatile IOs.
LINE OUT1L	J6	RCA	Audio output 1L (1.2V RMS)
LINE OUT1R	J7	RCA	Audio output 1R (1.2V RMS)
	J8 (Optional, n.m.)	1*3	Audio output 1 stereo (1.2V RMS)
LINE OUT2L	J9	RCA	Audio output 2L (1.2V RMS)
LINE OUT2R	J10	RCA	Audio output 2R (1.2V RMS)
	J11 (Optional, n.m.)	1*3	Audio output 2 stereo (1.2V RMS)
LINE IN	J12	Mini Jack	Audio input channels 0-1 (1V RMS)
	J13 (Optional, n.m.)	1*3	Audio input channels 0-1 (1V RMS)
SPDIF OUT	J14	DLT2160A	SPDIF Audio Optical Output
SPDIF IN	J15	DLR2160	SPDIF Audio Optical Input
ANALOG INPUTS	J16	JST XH Series, 1*5	Analog inputs for potentiometers
To 5000USBH-IF	J17	HARWIN M22 2*3	Connection for USB drive adapter: 5000USBH-IF
USB POWER SUPPLY & USB DEVICE PORT	J18	Mini USB B	USB connector used to power the board. Can also be used as USB device full or high speed port.
POWER SUPPLY	J19 (Optional, n.m.)	1*2	Power supply if JD1 open, +5V/0.5A, GND on pin 1
USB DEVICE PORT	J20 (Optional, n.m.)	1*4	USB device full or high speed port if J18 is not used.

“n.m.” = not mounted

Jumper Configuration

Reference	Default Setting	Description
JMP1	1-2	Select I2S or SPDIF audio input hardware for DAAD0-SPDIF_IO multiplexed pin: <ul style="list-style-type: none"> 1-2: I2S hardware input (DAAD0 primary function) 2-3: SPDIF hardware input (SPDIF_IO secondary function) Note: Primary and secondary function on a same pin are mutually exclusives.
JMP2	Closed	Connect DABD1 to U7 (LINE OUT 2).
JMP3	1-2	Select I2S or SPDIF audio output hardware for DABD0-SPDIF_OI multiplexed pin: <ul style="list-style-type: none"> 1-2: I2S hardware output (DABD0 primary function) 2-3: SPDIF hardware output (SPDIF_OI secondary function) Note: Primary and secondary function on a same pin are mutually exclusives.
JMP4	0	Main Oscillator OSC1 frequency select: <ul style="list-style-type: none"> JMP5 -> 0, JMP4 -> 0 : 12 MHz (default) JMP5 -> 0, JMP4 -> 1 : 9.6 MHz JMP5 -> 1, JMP4 -> 0 : 11.2896 MHz JMP5 -> 1, JMP4 -> 1 : 12.288 MHz
JMP5	0	
JD1	Closed	Power supply source <ul style="list-style-type: none"> Closed: Power supply from USB VBUS Open: Power supply from J19
JD2	Closed	For test and measurement on 3.3V power supply

Layout

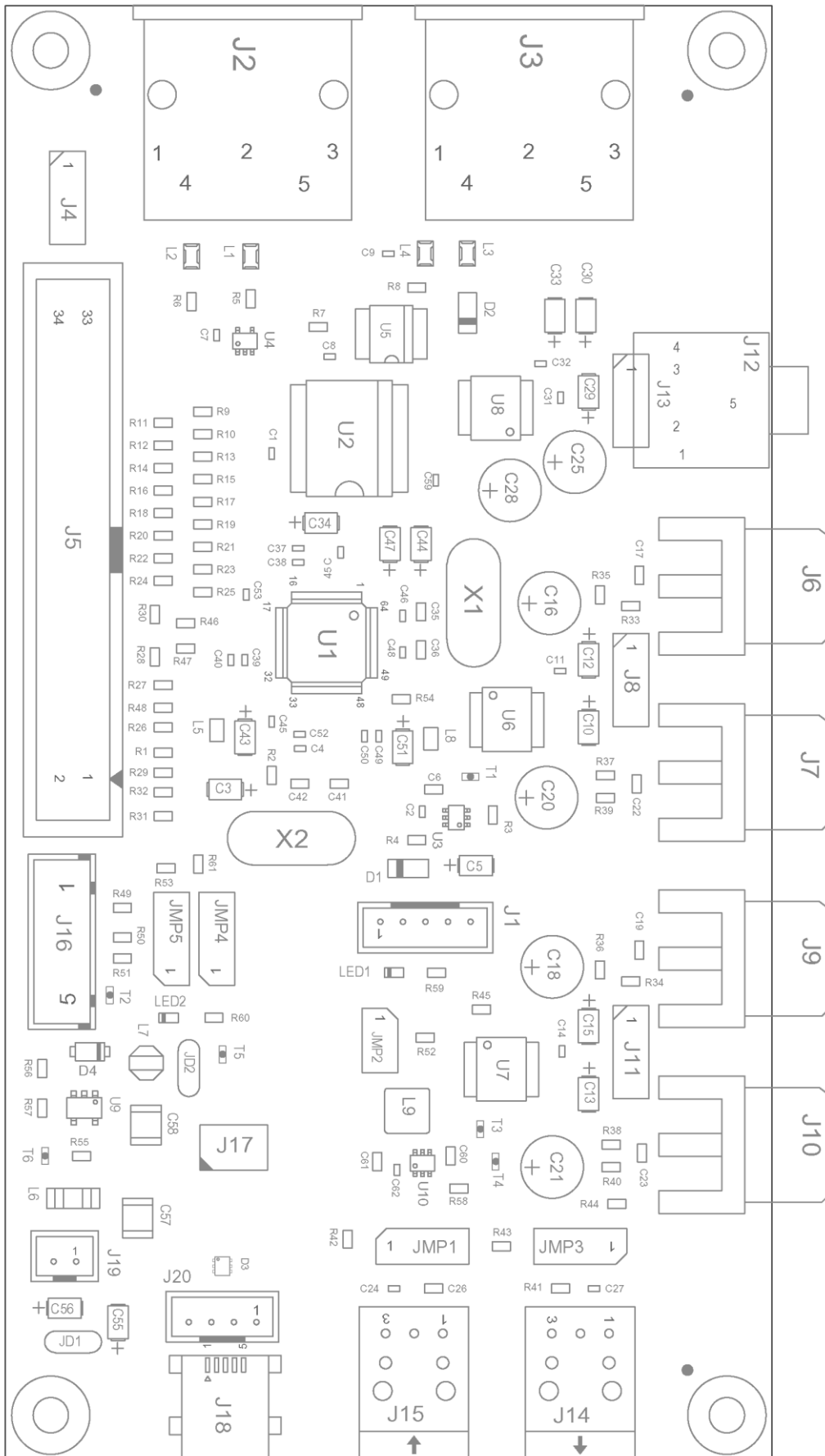

Bill of Material

SAM5504B - Development Board Revised: Tuesday, March 10, 2017

5504-DK.DSN Revision: 1

Page 1

Item	Quantity	Reference	Part	Manufacturer	Designation
1	22	C1, C2, C4, C7, C8, C9, C11, C14, C24, C27, C31, C32, C37, C39, C45, C46, C48, C49, C52, C53, C54, C62	100nF		
2	11	C3, C10, C12, C13, C15, C30, C33, C34, C43, C47, C51	10 μ F-T-10V		
3	2	C5, C44	4.7 μ F-T-10V		
4	1	C6	470pF		
5	4	C16, C18, C20, C21	22 μ F-Low dist	PANASONIC	ECA1HAM220X
6	4	C17, C19, C22, C23	2.2nF		
7	2	C25, C28	10 μ F-Low Dist	PANASONIC	ECA1HAM100X
8	1	C26	30pF		
9	1	C29	2.2 μ F-T-10V		
10	4	C35, C36, C41, C42	22pF		
11	3	C38, C50, C59	470pF		
12	1	C40	10nF		
13	2	C55, C56	1 μ F-T		
14	2	C57, C58	22 μ F-X5R		
15	2	C60, C61	10 μ F-X5R		
16	2	D1, D2	LL4148	VISHAY	LL4148
17	1	D3	TPD2E1B06	TI	TPD2E1B06
18	1	D4	CRS08	TOSHIBA	CRS08
19	2	JD1, JD2	Jumper Disk1P		
20	4	JMP1, JMP3, JMP4, JMP5	Jumper2P	Generic	BA25-Male-7mm-Gold
21	1	JMP2	Jumper1P	Generic	BA25-Male-7mm-Gold
22	1	J1	B5B-PH-K-S	JST	B5B-PH-K-S
23	2	J2, J3	MIDI_DIN		
24	1	J4	HEAD_3	Generic	BA25-Male-7mm-Gold
25	1	J5	HEAD_17X2		
26	4	J6, J7, J9, J10	RCA_JACK	KEYSTONE	901
27	2	J8, J11	N.M.		
28	1	J12	JACK 3.5 STEREO	3E	15.427
29	1	J13	N.M.		
30	1	J14	DLT2160A	AIXIN OPTO-ELECTRICAL	DLT2160A
31	1	J15	DLR2160	AIXIN OPTO-ELECTRICAL	DLR2160

Item	Quantity	Reference	Part	Manufacturer	Designation
32	1	J16	B5B-XH-A	JST	B5B-XH-A
33	1	J17	M22-2020305	HARWIN	M22-2020305
34	1	J18	651 005 161 21	WERI	651 005 161 21
35	1	J19	N.M.	JST	B2B-PH-K-S
36	1	J20	N.M.	JST	B4B-PH-K-S
37	1	LED1	TLMG1100-Vishay	VISHAY	TLMG1100
38	1	LED2	TLMS1000-Vishay	VISHAY	TLMS1000-GS08
39	4	L1, L2, L3, L4	NFM21CC102R1H3	MURATA	NFM21CC102R1H
40	2	L5, L8	742792093	WURTH	742792093
41	1	L6	NFM41PC204F1H3	MURATA	NFM41PC204F1H3
42	1	L7	744029003	WURTH	744029003
43	1	L9	744031004	WURTH	744777003
44	10	R1, R2, R3, R4, R35, R36, R39, R40, R53, R61	10k		
45	3	R5, R6, R8	220		
46	1	R7	4.7k		
47	30	R9, R10, R11, R12, R13, R14, R15, R16, R17, R18, R19, R20, R21, R22, R23, R24, R25, R26, R27, R28, R29, R30, R31, R32, R42, R43, R46, R47, R48, R52	33		
48	4	R33, R34, R37, R38	330		
49	7	R41, R44, R45, R49, R50, R51, R55	100k		
50	1	R54	12k, 1%		
51	1	R56	45.3k 1%		
52	1	R57	10k 1%		
53	1	R58	0		
54	2	R59, R60	750		
55	6	T1, T2, T3, T4, T5, T6	TestPoint	Vogt	N.M. (985.62 or 1000C.22)
56	1	U1	SAM5504B_cfg1	DREAM	SAM5504B
57	1	U2	S25FL512SAGMFI01	SPANSION	S25FL512SAGMFI01
58	1	U3	74LVC1G57	TI	74LVC1G57DCK
59	1	U4	74LVC1G07	TI	74LVC1G07DCK
60	1	U5	HCPL-0501		
61	2	U6, U7	AK4384	AKM	AK4384VT
62	1	U8	AK5386	AKM	AK5386VT
63	1	U9	LM2830X	NS	LM2830X

Item	Quantity	Reference	Part	Manufacturer	Designation
64	1	U10	TPS61222	TI	TPS61222
65	1	X1	12.288MHz	FISCHER	PQ18+12.288MHz
66	1	X2	12MHz	FISCHER	PQ18+12MHz

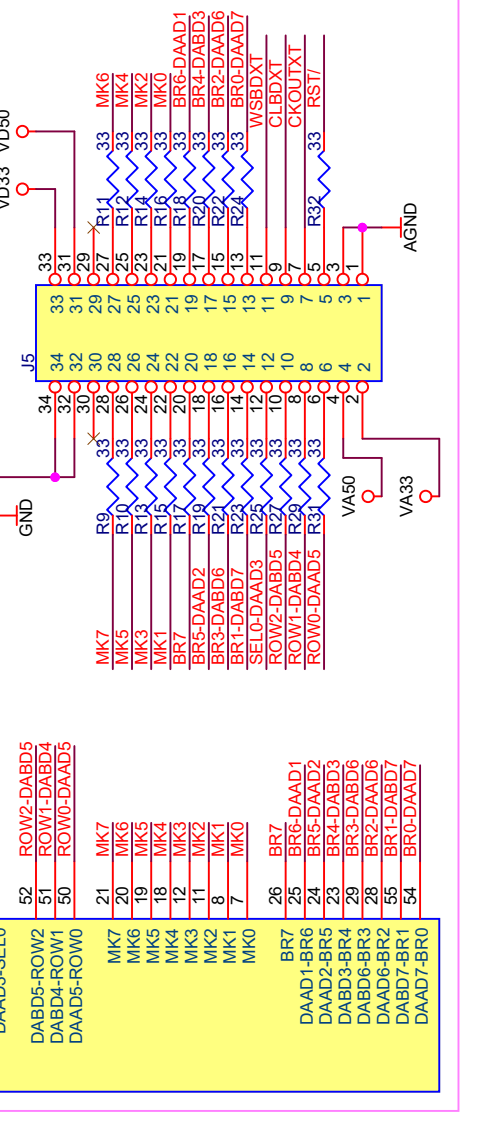
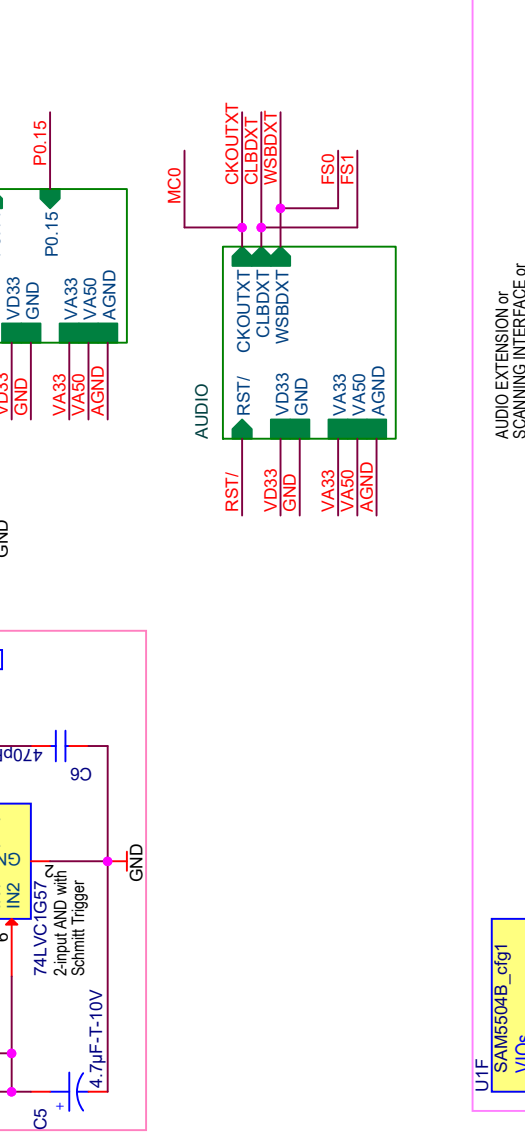
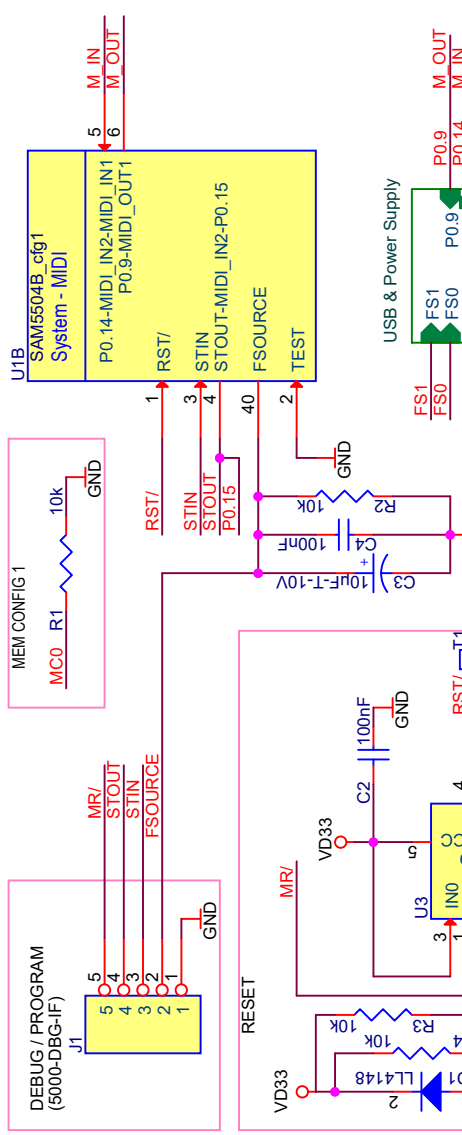
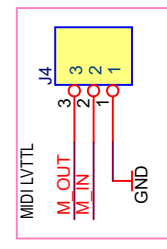
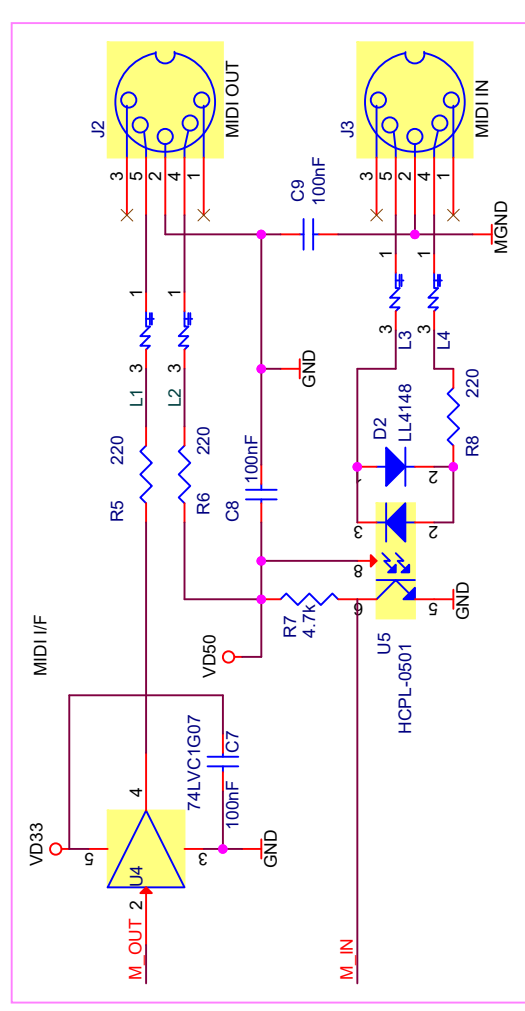
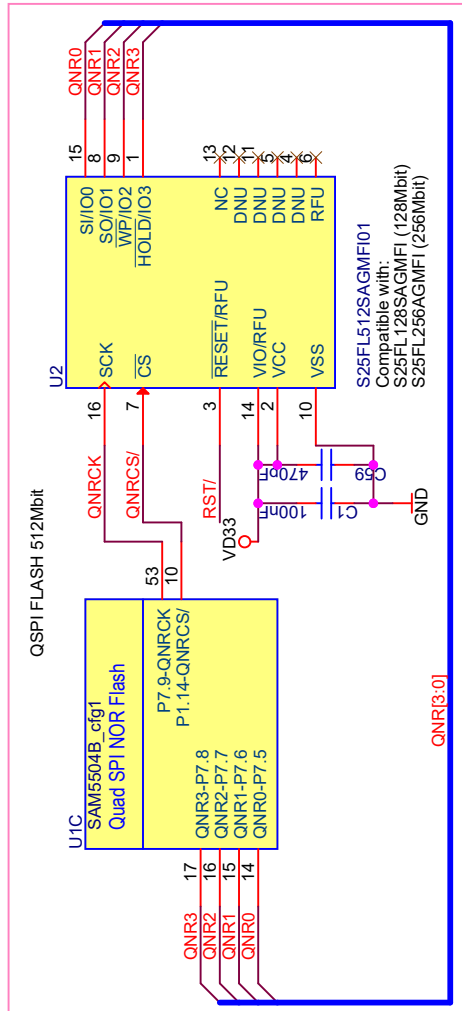

DREAM S.A.S. CONFIDENTIAL DATA

File SAM5504 - Development Board - Top: System & MIDI & Flash & Extensions

Size Document Number 5504-DK.DSN

Date: Tuesday, March 05, 2024 Sheet 1 of 3

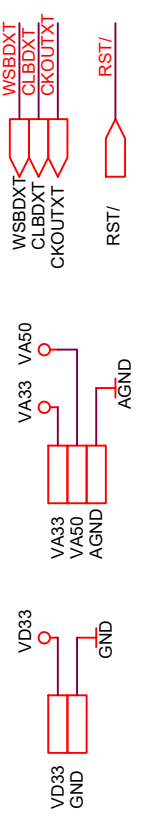
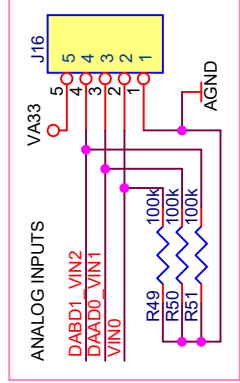
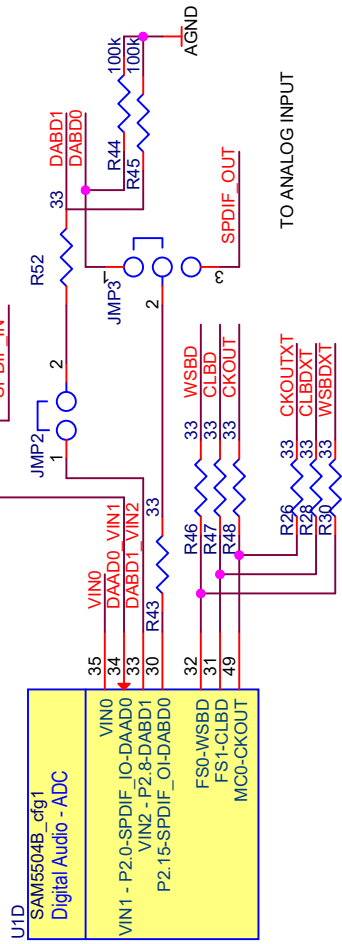
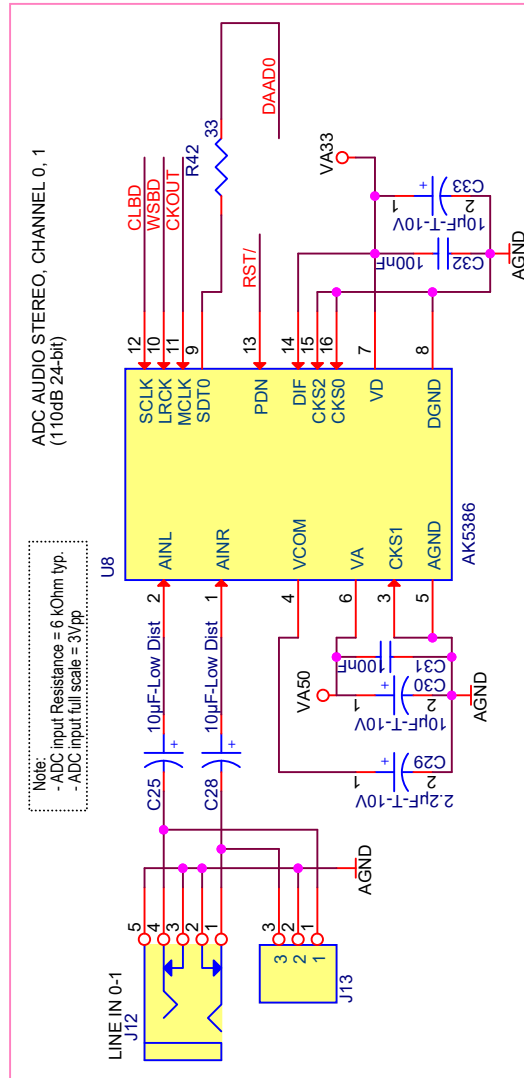
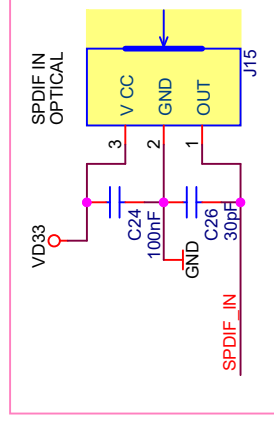
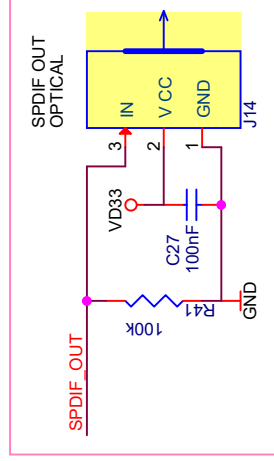
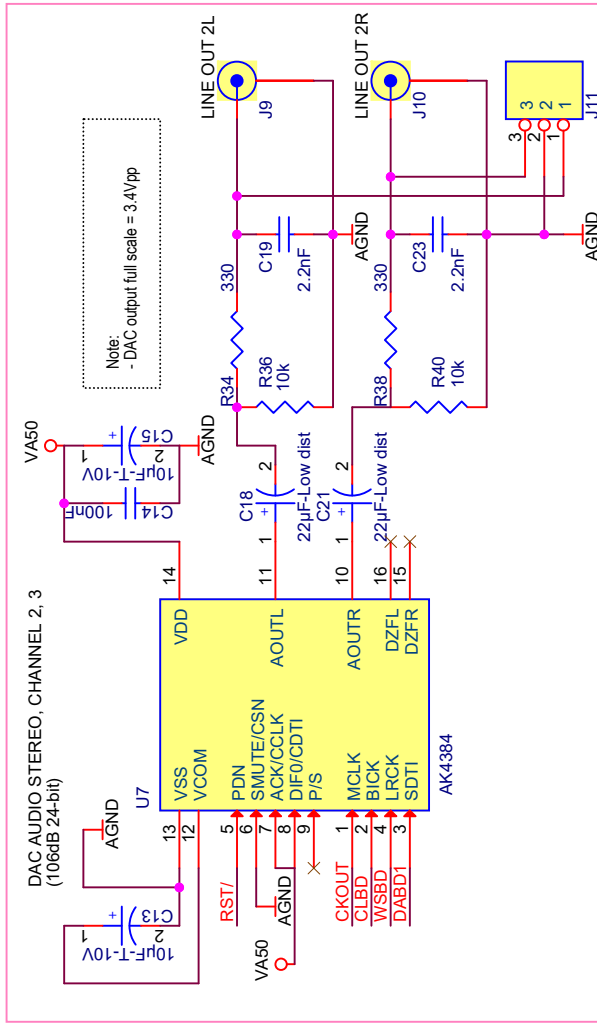
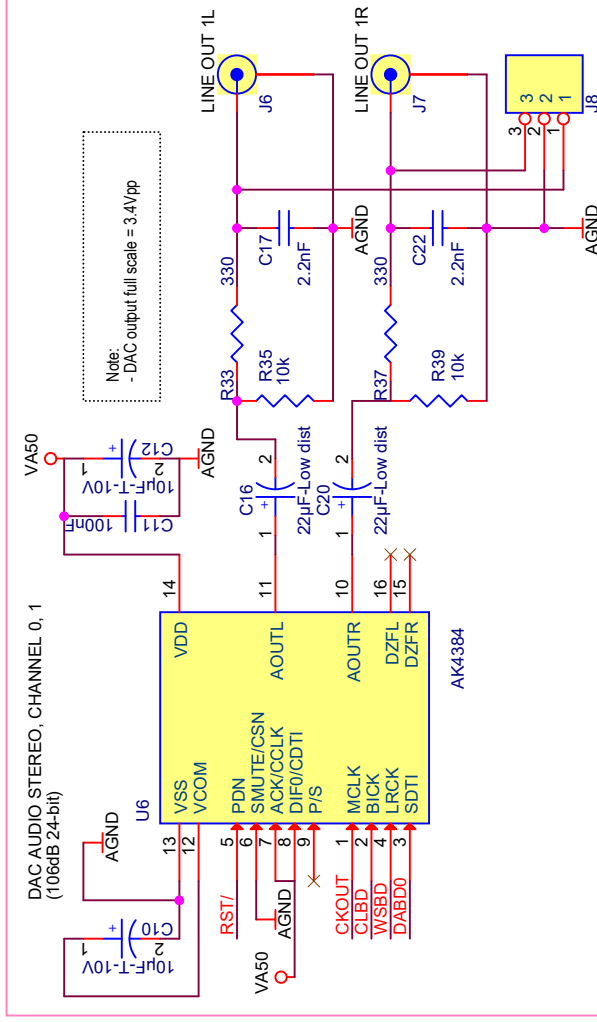

DREAM S.A.S. CONFIDENTIAL DATA

Title	SAM504 - Development Board - Audio
Size	Document Number 5504-DK.DSN
Date:	Tuesday, March 05, 2024
Sheet	2 of 3
Rev	1.1

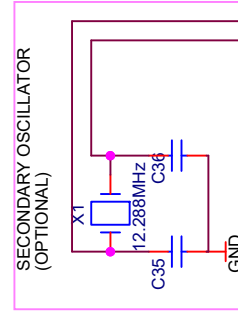
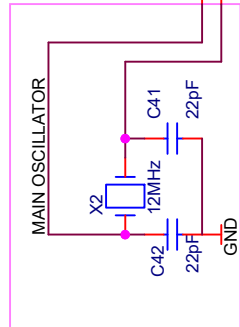
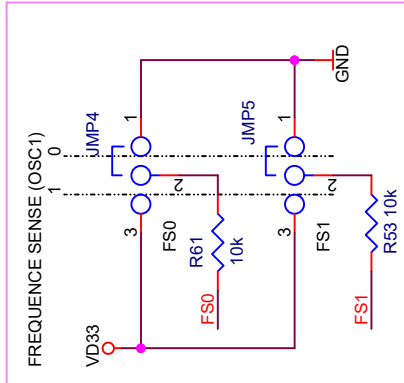
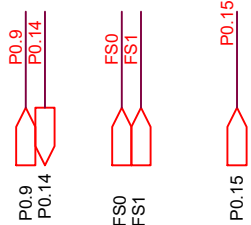

Freq (MHz)	FS1	FS0
12 (Default)	0	0
9.6	0	1
11.2896	1	0
12.288	1	1

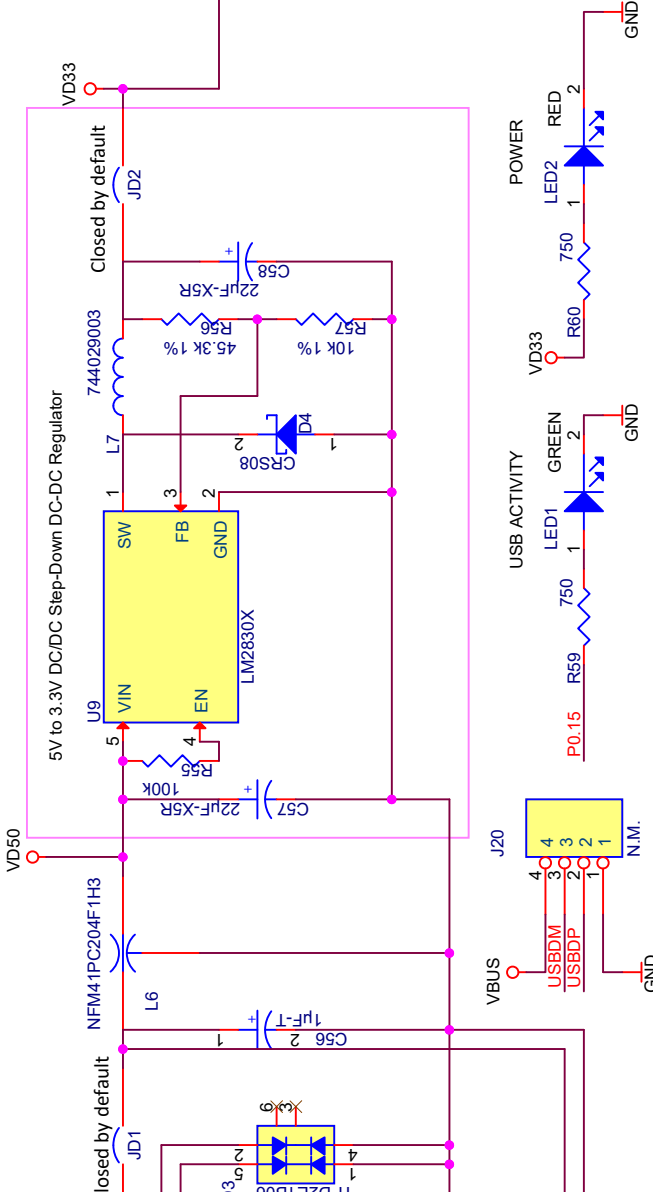
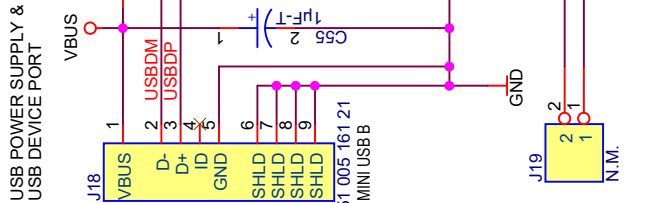
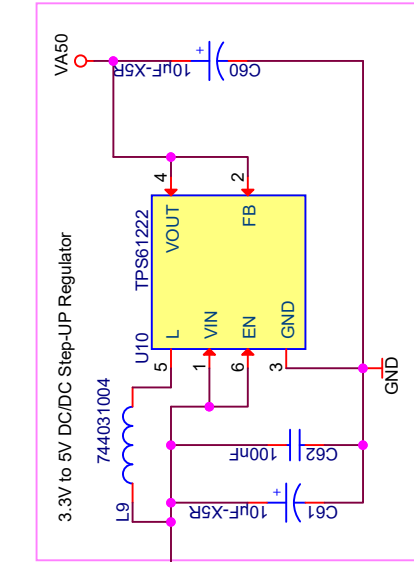
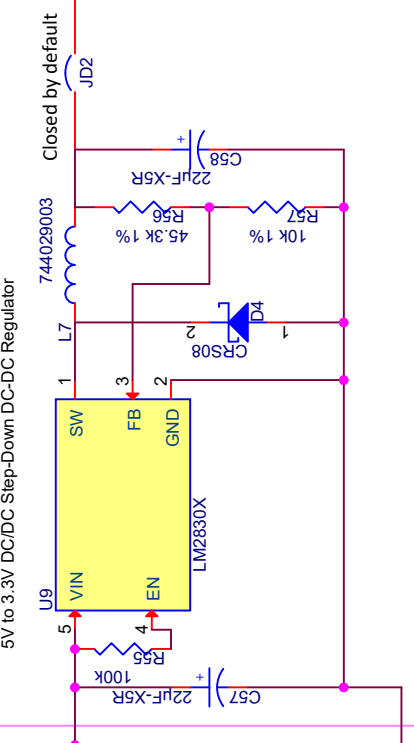
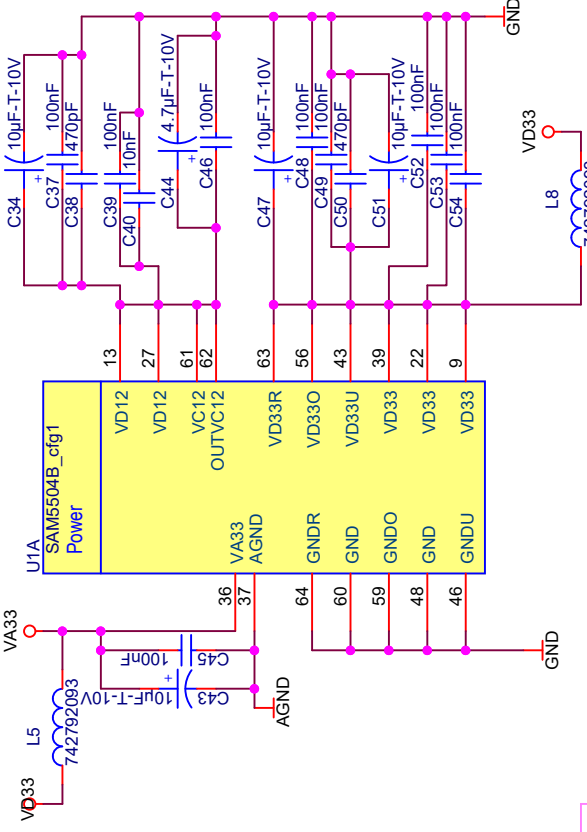
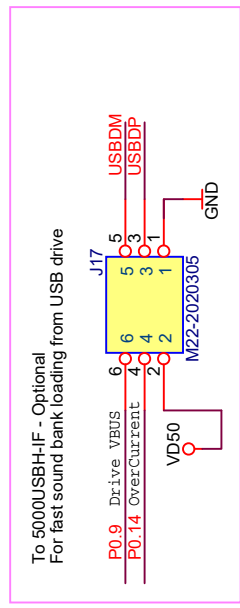

DREAM S.A.S. CONFIDENTIAL DATA

Title	SAM504 - Development Board - USB & Power Supply
Size	Document Number
A4	5504-DK.DSN
Date:	Tuesday, March 05, 2024
Sheet	3 of 3
Rev	1.1

Dream Contact

info@dream.fr

Website

<http://www.dream.fr>

This publication neither states nor implies any warranty of any kind, including, but not limited to, implied warrants of merchantability or fitness for a particular application. Dream assumes no responsibility for the use of any circuitry. No circuit patent licenses are implied. The information in this publication is believed to be accurate in all respects at the time of publication but is subject to change without notice. Dream assumes no responsibility for errors and omissions, and disclaims responsibility for any consequences resulting from the information included herein.