

DREAM S.A.S. CONFIDENTIAL DATA

Title		
SAM5504 - Development Board - Top: System & MIDI & Extensions		
Size	Document Number	Rev
A4	5504USB-DK.DSN	0
Date:	Wednesday, October 06, 2021	Sheet 1 of 9

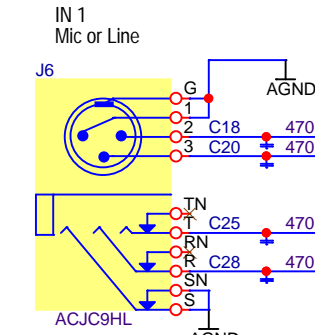
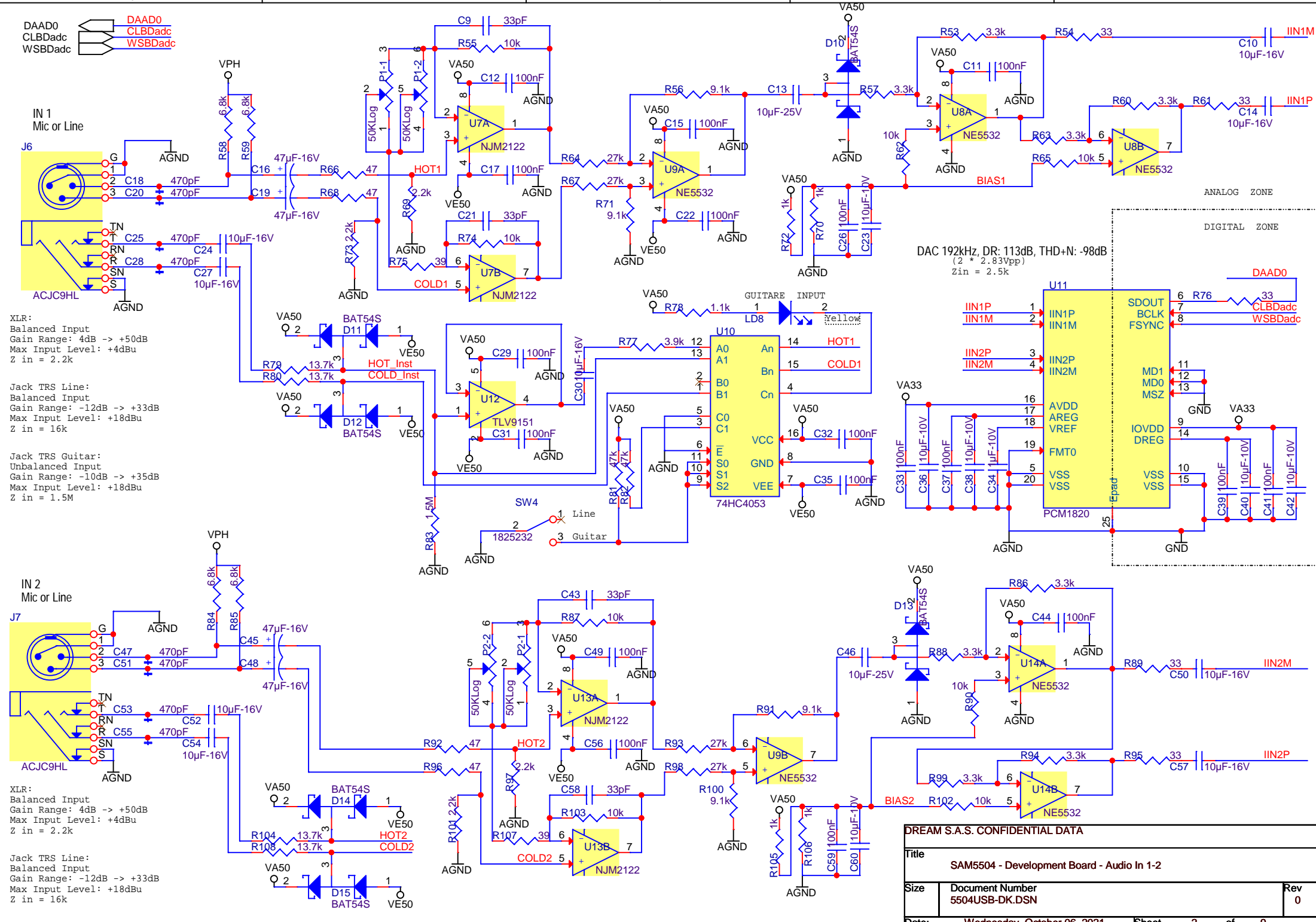

**IN 1**  
Mic or Line

**J6**  
ACJC9HL

**XLR:**  
Balanced Input  
Gain Range: 4dB -> +50dB  
Max Input Level: +4dBu  
Z in = 2.2k

**Jack TRS Line:**  
Balanced Input  
Gain Range: -12dB -> +33dB  
Max Input Level: +18dBu  
Z in = 16k

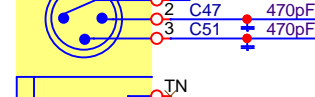
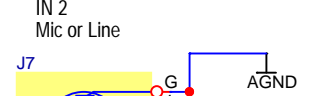

**IN 2**  
Mic or Line

**J7**  
ACJC9HL

**XLR:**  
Balanced Input  
Gain Range: 4dB -> +50dB  
Max Input Level: +4dBu  
Z in = 2.2k

**Jack TRS Line:**  
Balanced Input  
Gain Range: -12dB -> +33dB  
Max Input Level: +18dBu  
Z in = 16k

DAC 192kHz, DR: 113dB, THD+N: -98dB  
(2 \* 2.83Vpp)  
Zin = 2.5k

DREAM S.A.S. CONFIDENTIAL DATA

Title		
SAM5504 - Development Board - Audio In-2		
Size	Document Number	Rev
	5504USB-DK.DSN	0
Date:	Wednesday, October 06, 2021	Sheet 2 of 9

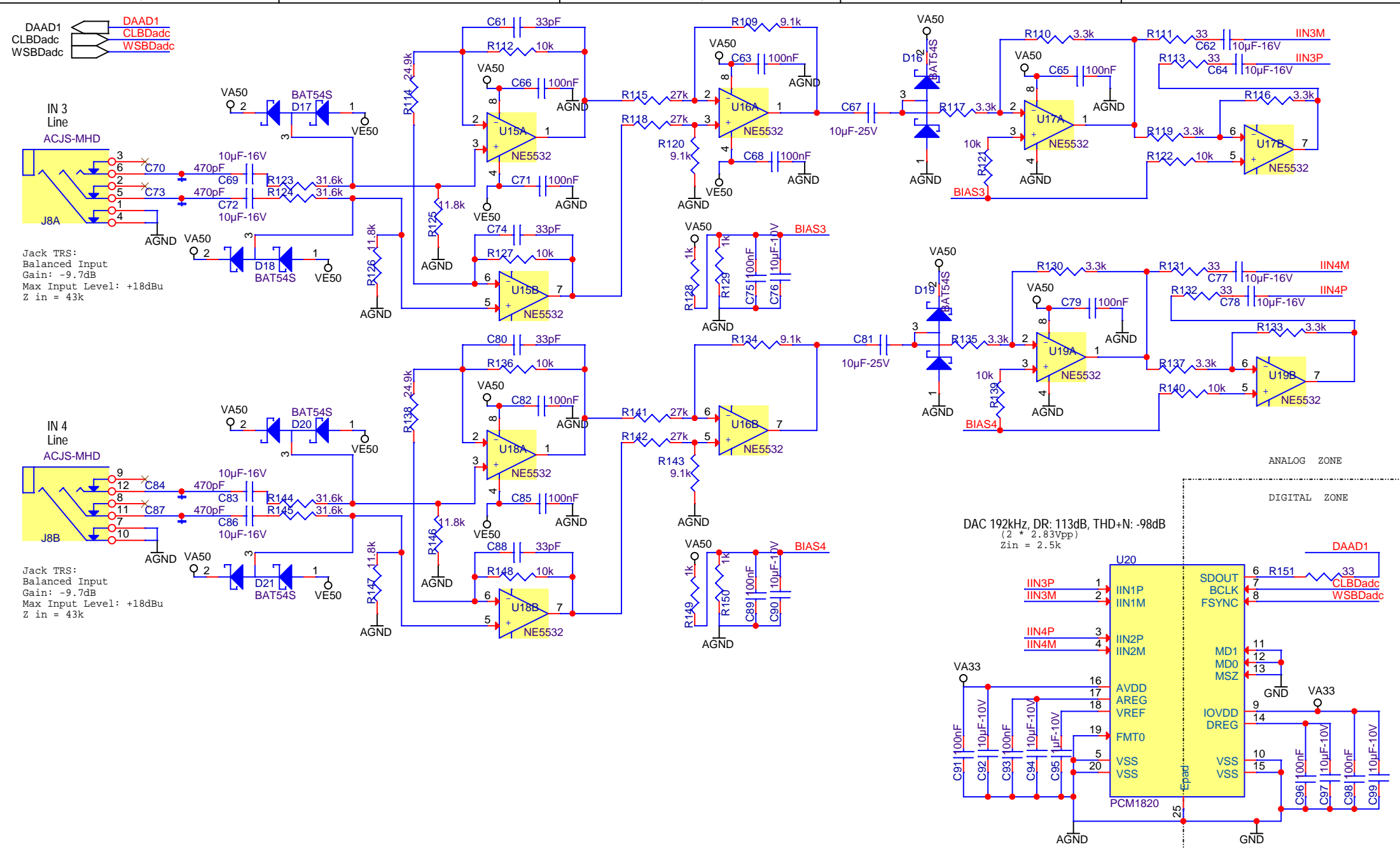

Jack TRS:  
Balanced Input  
Gain: -9.7dB  
Max Input Level: +18dBu  
Z in = 43k

Jack TRS:  
Balanced Input  
Gain: -9.7dB  
Max Input Level: +18dBu  
Z in = 43k

DAC 192kHz, DR: 113dB, THD+N: -98dB  
(2 \* 2.83Vpp)  
Zin = 2.5k

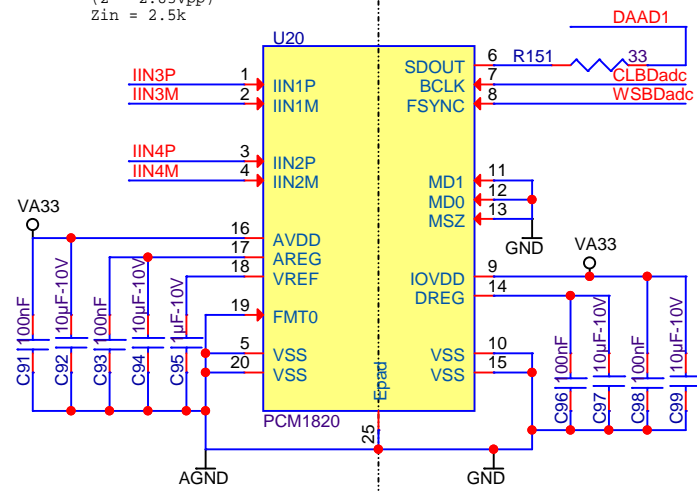

DREAM S.A.S. CONFIDENTIAL DATA			
Title SAM5504 - Development Board - Audio In 3-4			
Size	Document Number 5504USB-DK.DSN	Rev 0	
Date:	Wednesday, October 06, 2021	Sheet	3 of 9

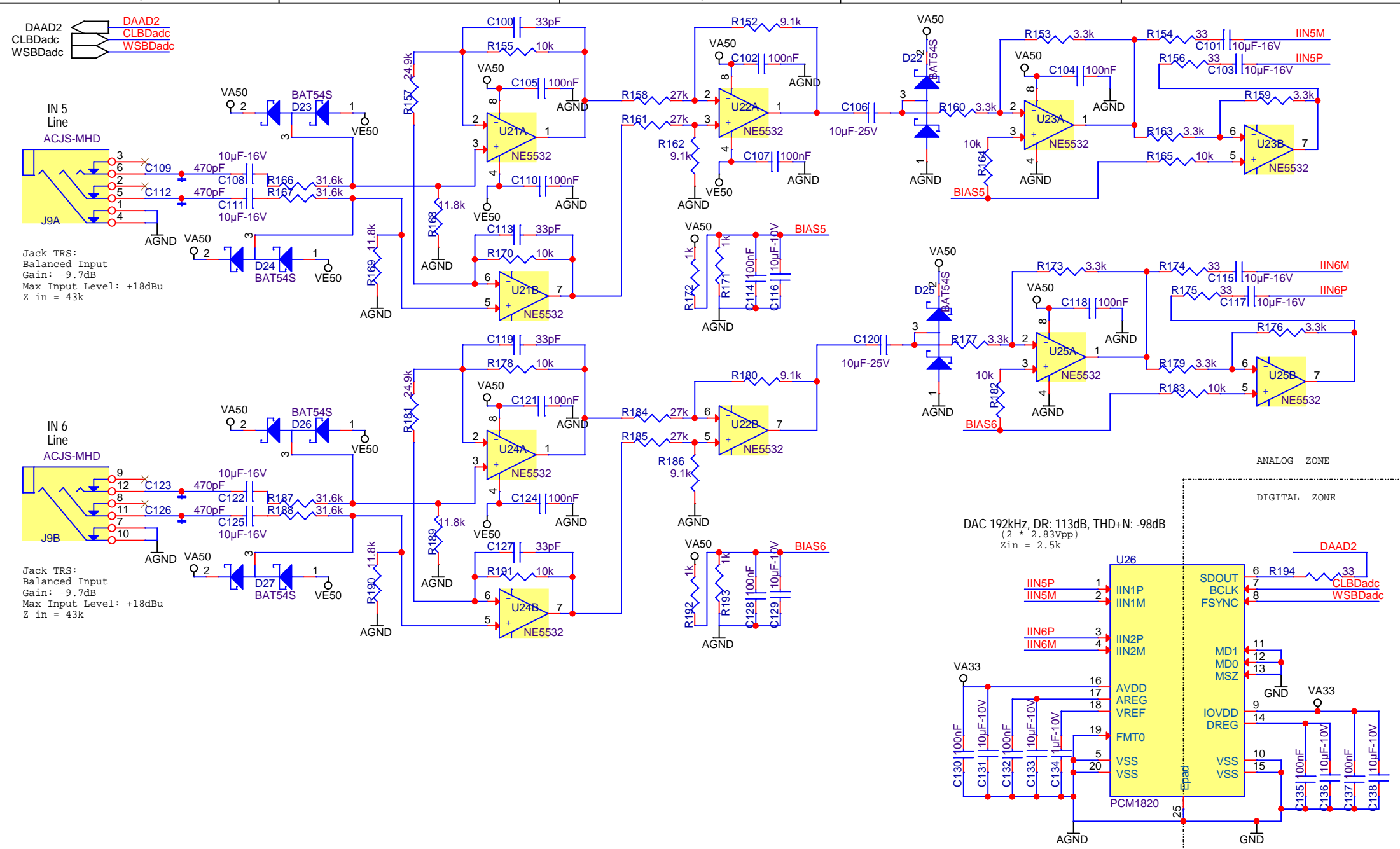

Jack TRS:  
Balanced Input  
Gain: -9.7dB  
Max Input Level: +18dBu  
Z in = 43k

Jack TRS:  
Balanced Input  
Gain: -9.7dB  
Max Input Level: +18dBu  
Z in = 43k

DAC 192kHz, DR: 113dB, THD+N: -98dB  
(2 \* 2.83Vpp)  
Zin = 2.5k

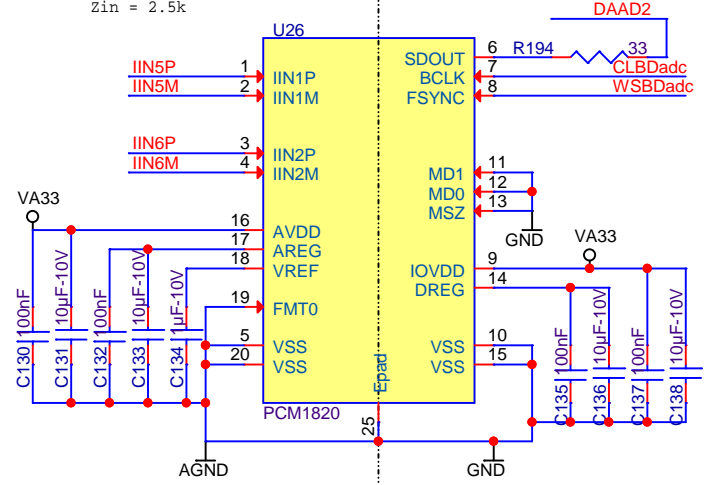

DREAM S.A.S. CONFIDENTIAL DATA

Title		
SAM5504 - Development Board - Audio In 5-6		
Size	Document Number	Rev
	5504USB-DK.DSN	0
Date:	Friday, October 08, 2021	Sheet 4 of 9

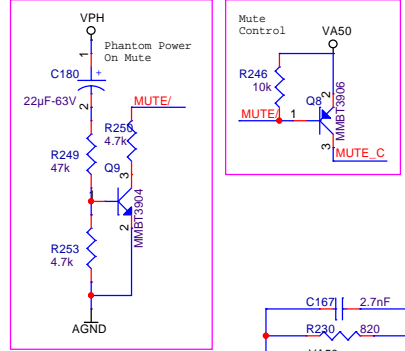
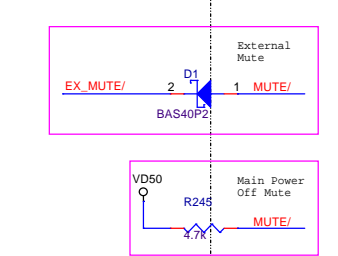
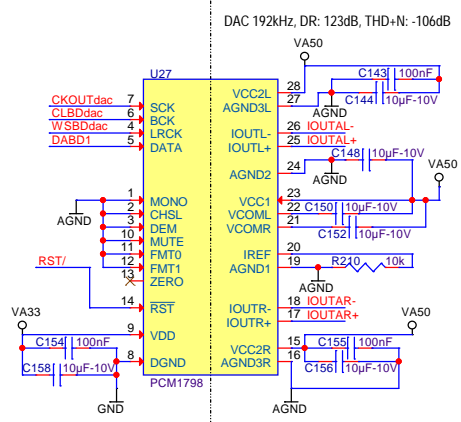

Geographical Limit between Digital and Analog Zones

DIGITAL ZONE ANALOG ZONE

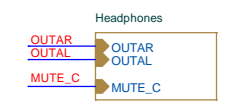
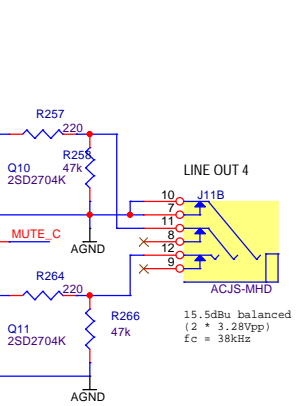
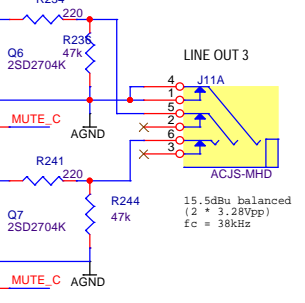
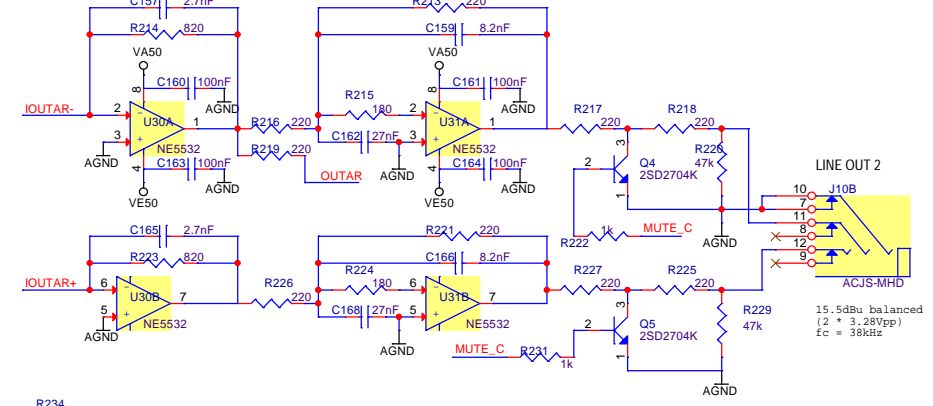
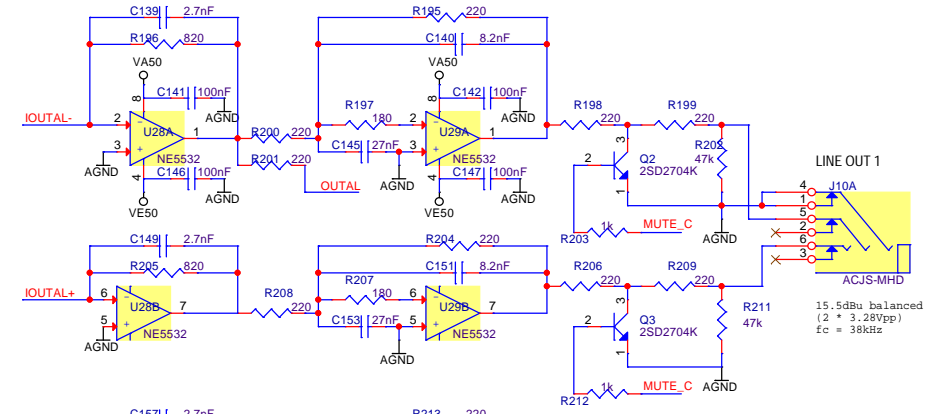
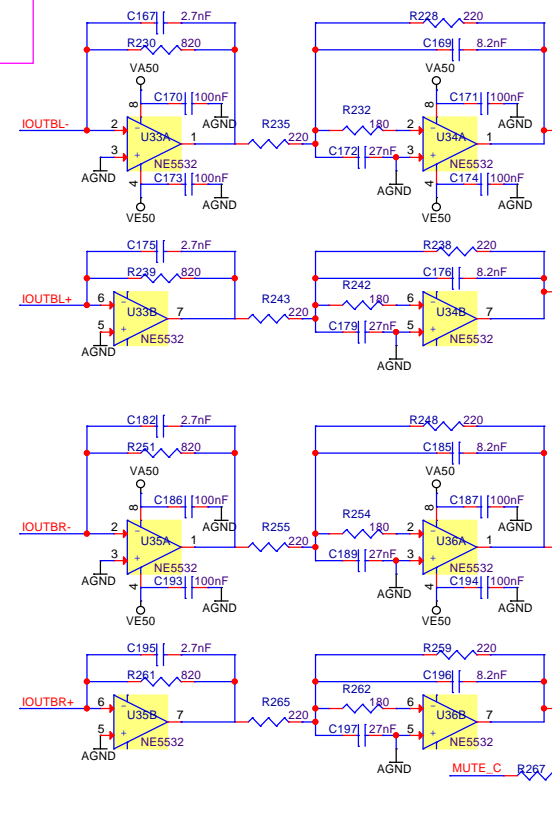
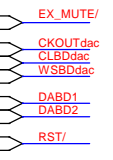
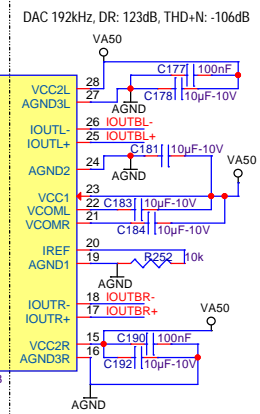

DREAM S.A.S. CONFIDENTIAL DATA		
File	SAM5504 - Development Board - Audio Outputs	
Size	Document Number	Rev
	5504USB-DK.DSN	0
Date:	Wednesday, October 06, 2021	Sheet 5 of 9



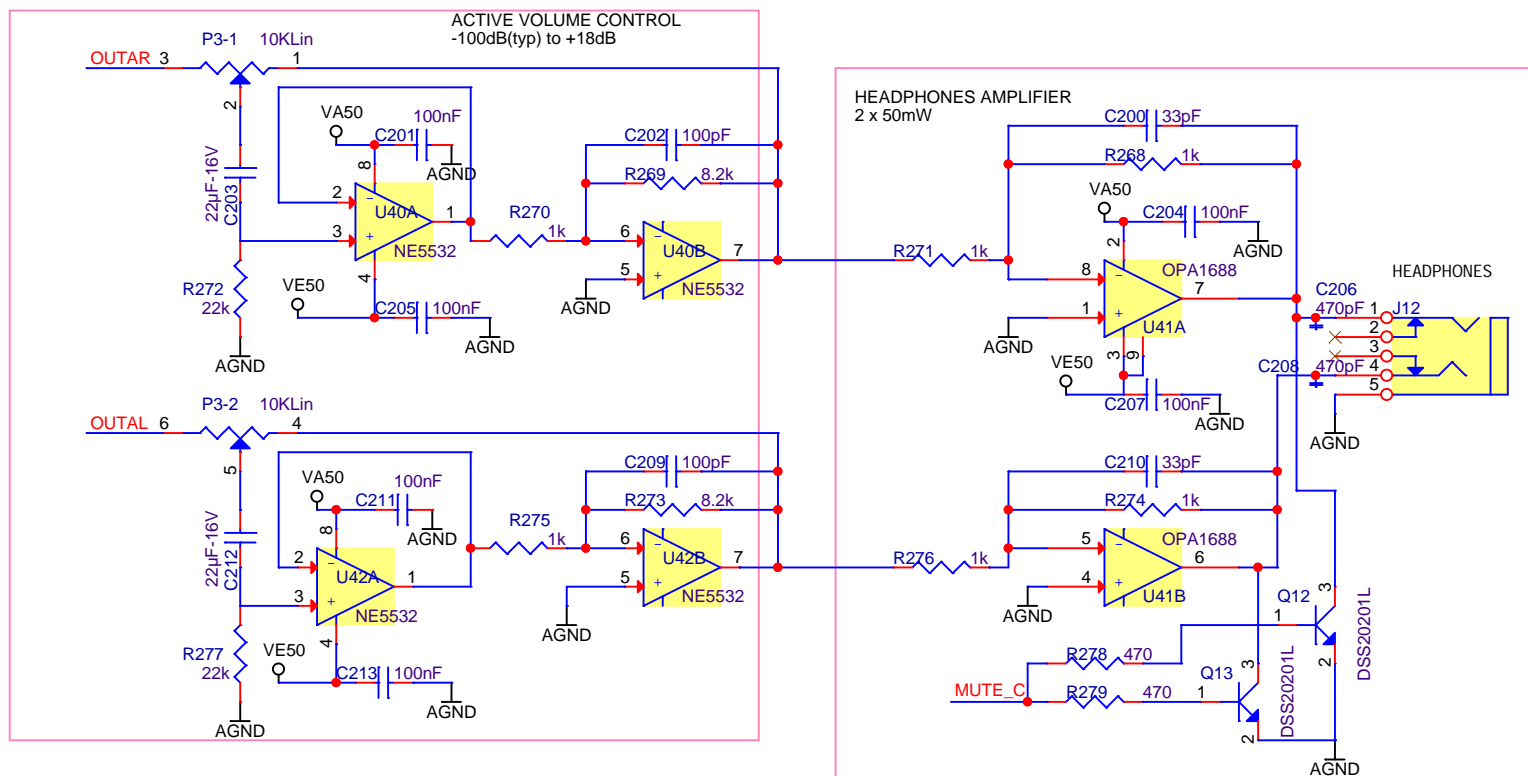
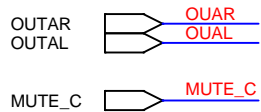

DREAM S.A.S. CONFIDENTIAL DATA		
Title SAM5504 - Development Board - Headphones		
Size	Document Number 5504USB-DK.DSN	Rev 0
Date:	Wednesday, October 06, 2021	Sheet 7 of 9



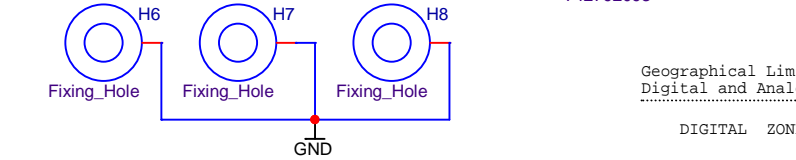
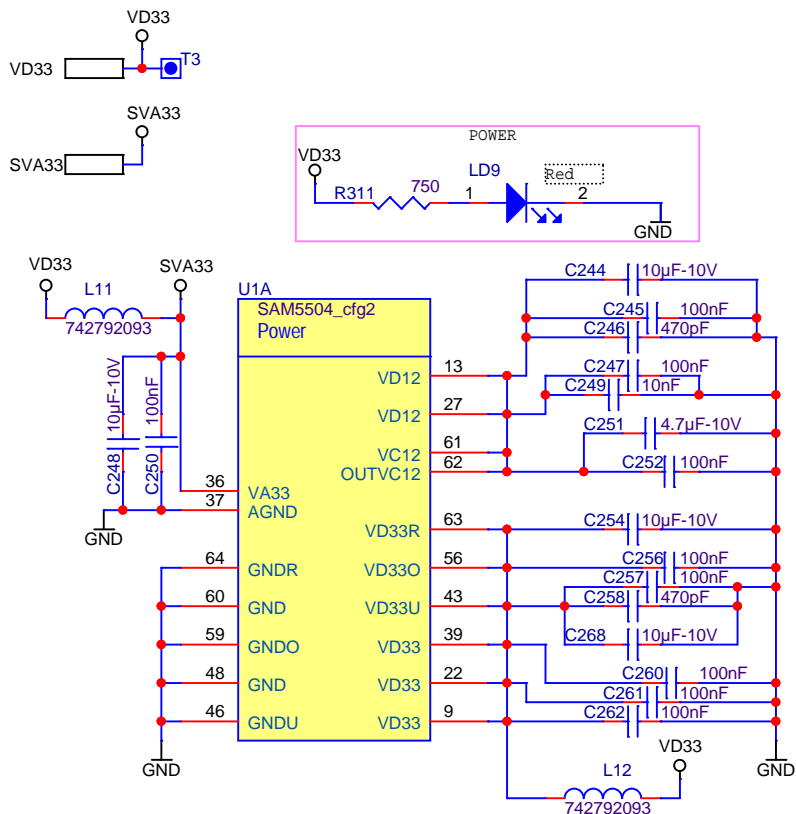

Geographical Limit between Digital and Analog Zones

DIGITAL ZONE

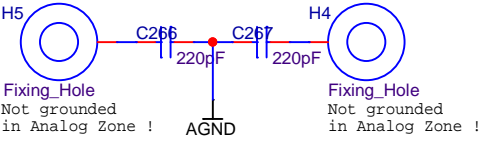
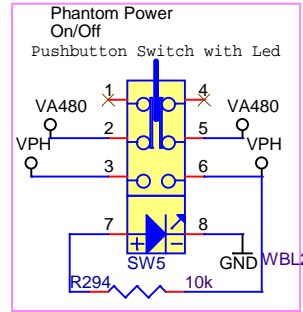
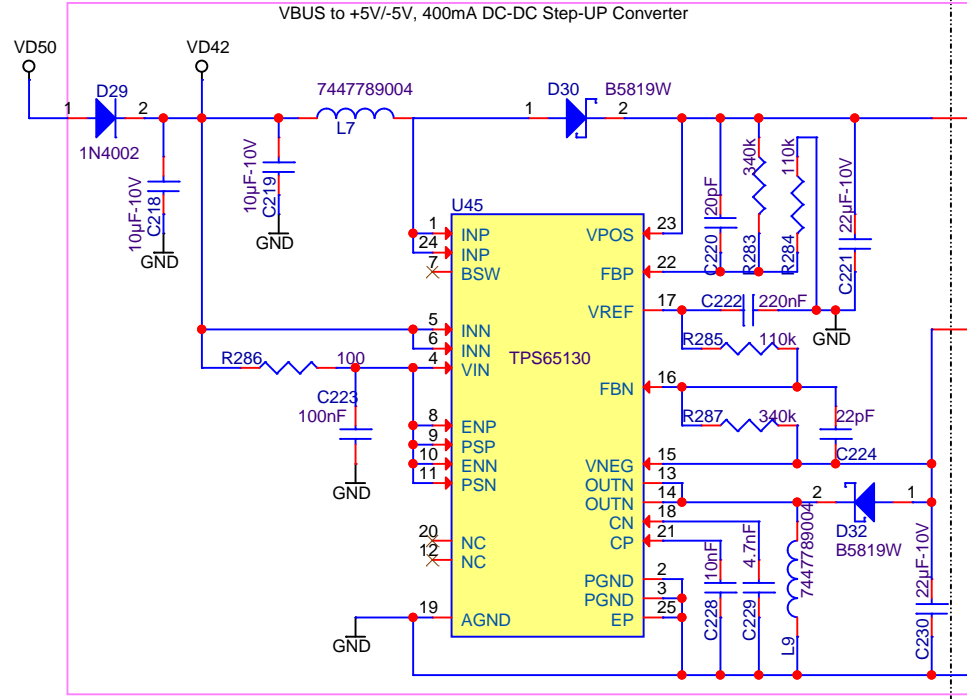
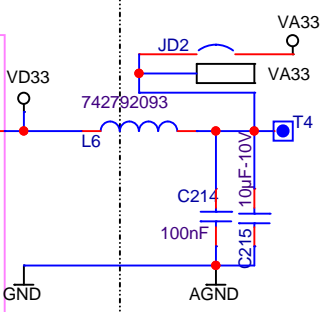
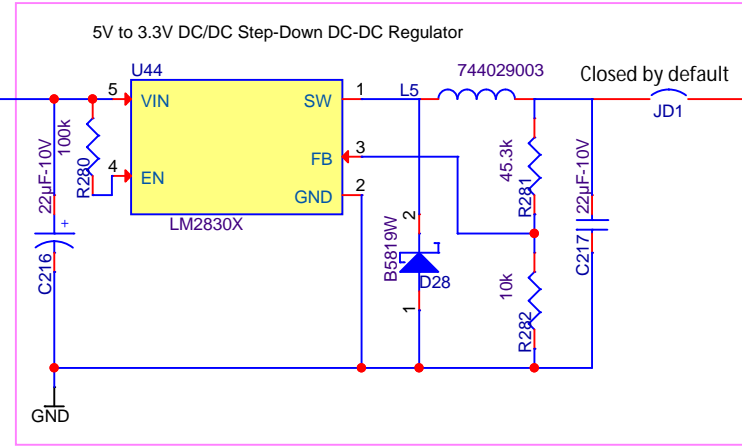
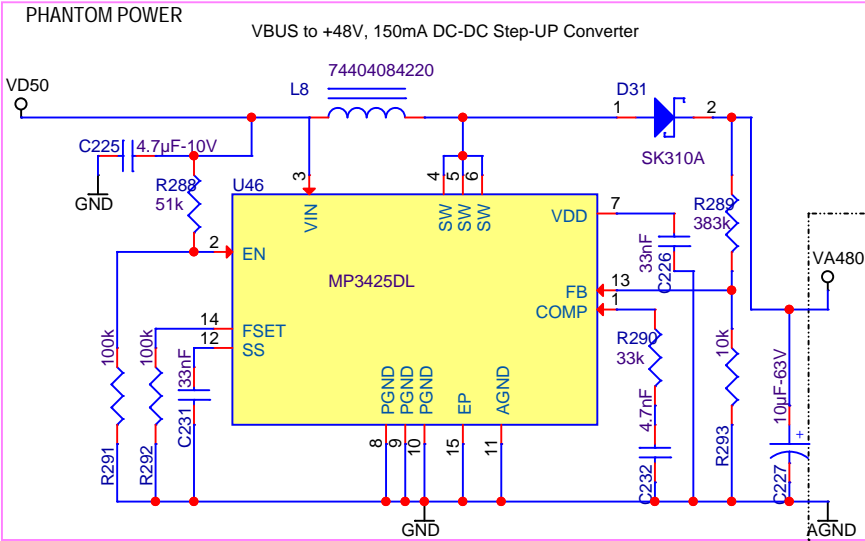

DREAM S.A.S. CONFIDENTIAL DATA			
Title SAM5504 - Development Board - Power Supply			
Document Number 5504USB-DK.DSN		Rev 0	
Date: Wednesday, October 06, 2021	Sheet 8		of 9



SPDIF\_IN  
SPDIF\_OUT

SPDIF IN  
J13

PWM  
SDA  
SCL

FS0  
FS1  
USB\_ACT

VD50  
GND

USB ACTIVITY  
LD10

USB POWER SUPPLY &  
USB DEVICE PORT

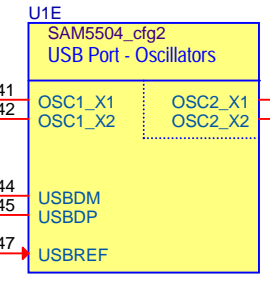
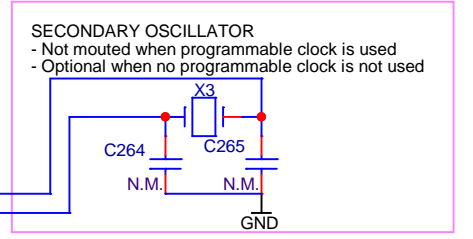
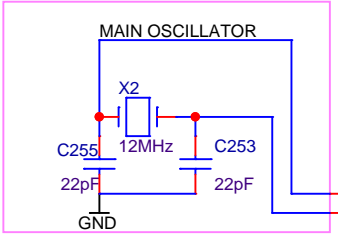
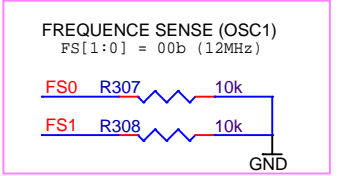
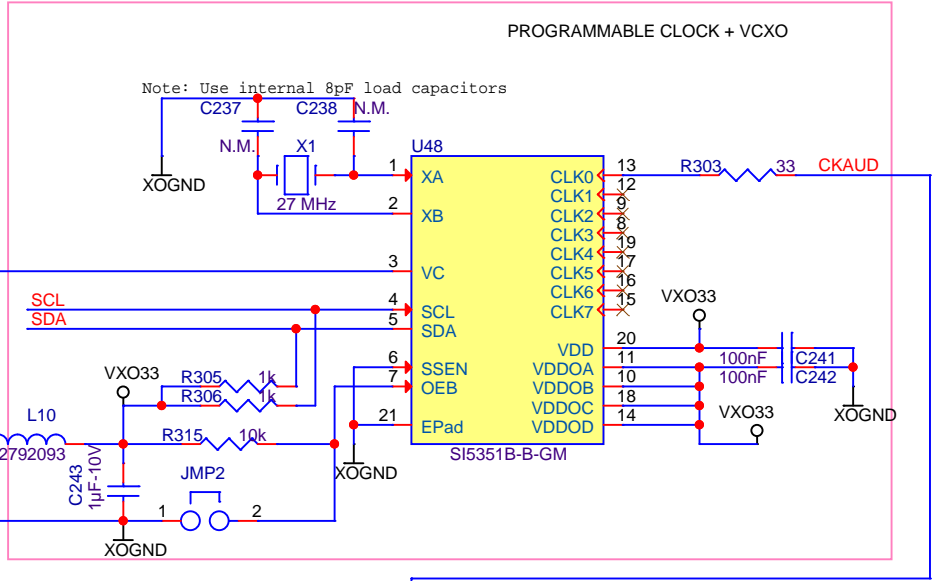
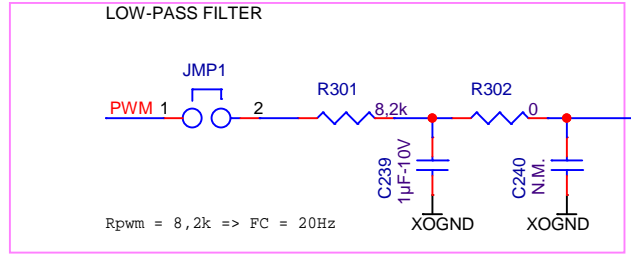
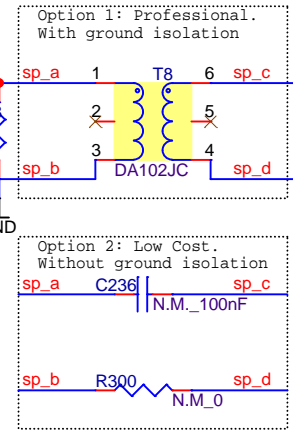
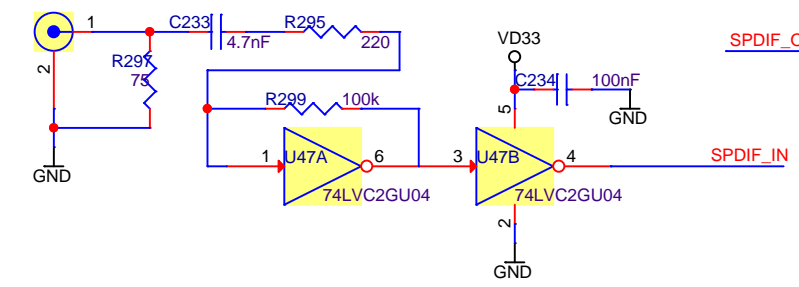
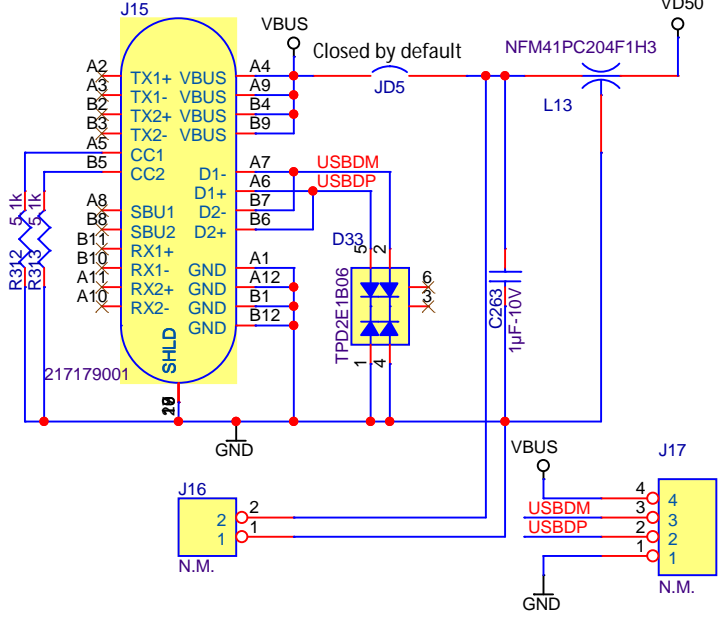

DREAM S.A.S. CONFIDENTIAL DATA			
Title SAM5504 - Development Board - USB & SPDIF & Oscillators			
Size A4	Document Number 5504USB-DK.DSN	Rev 0	
Date Wednesday, October 06, 2021	Sheet 9	of 9	