

Overview

5704PIA-DK is a high quality stand-alone evaluation board based on SAM5704 (AUDIO & MUSIC MULTI-DSP PROCESSOR).

The SAM5704 can be used in 6 different hardware configurations for different applications. On 5704PIA-DK board the SAM5704 is running in the hardware configuration dedicated to digital pianos and keyboard instruments built around low cost Quad SPI memory components.

Samples are stored in Quad SPI Flash and read from it in Quad I/O Read Mode (100MHz) through the SAM5704 Sample Cache Controller to reach 81-voice polyphony. Octal SPI is even possible with 2 Quad SPI devices.

Beside the SAM5704, the 5704PIA-DK_Rev0 hardware includes:

- 1 Audio CODEC: AKM AK4556 (24bit | ADC: S/N=103dB, S/N+D=91dB | DAC: S/N=106dB, S/N+D=90dB)
- 256Mbit Quad SPI Flash Memory: SPANSION S25FL256SAGMFI001
- Additional 256Mbit Quad SPI Flash Memory (optional): SPANSION S25FL256SAGMFI001 for Octal SPI mode
- DataFlash® memory ATMEL AT45DB041E, for Boot, MIDI song recording/playback and data storage
- SD-Card socket
- USB High Speed - Device mode

Hardware Configuration

This reference design kit also includes a front panel. It is designed to be connected with an 88-note velocity sensitive piano keyboard.

Operating Mode

5704PIA-DK operates on two modes:

- Debug mode:
The board is connected to a PC through the Dream 5000DBG-IF adaptor. The firmware can be downloaded and debugged into Quad SPI Flash memory with Dream SamVS-C development software. With SamVS or ProgSam software tool it is possible to program the firmware in Quad SPI flash memory for stand-alone mode.
- Stand-alone mode:
In this mode the SAM5704 executes the program from the Quad SPI Flash memory and scans the front panel and the piano keyboard. Optionally, firmware and Quad SPI Flash data can be updated from this mode.

Connectors Configuration

Name	Reference	Type	Description
DEBUG / PROGRAM	J3	1*5	Serial connection for debug and program, compatible with Dream 5000DBG-IF
MIDI OUT	J4	5-pin Din	Standard MIDI OUT at 31.25kb/s
MIDI IN	J5	5-pin Din	Standard MIDI IN at 31.25kb/s
LINE OUT RIGHT	J6	RCA	Right audio output (0.8V RMS)
LINE OUT LEFT	J7	RCA	Left audio output (0.8V RMS)
	J8 (Optional, n.m.)	1*3	Stereo audio output (0.8V RMS)
AUDIO IN	J9	Mini Jack	Stereo audio input (0.02 to 1V RMS)
	J10 (Optional, n.m.)	1*3	Stereo audio input (0.02 to 1V RMS)
AUDIO EXTENSION	J11 (Optional, n.m.)	1*9	Extension for additional digital audios I/Os
9V 1A DC	J12	DC Plug	Power Supply, +9V...12V/1A, minus on dip
	J13 (Optional, n.m.)	1*2	Power Supply, +9V...12V/1A
PEDALS INPUT	J14	1*4	Connection for pedals (analog inputs)
	J15 (Optional)	1*4	Connection for further analog controls
KEYBOARD HIGHER PART	J16	2*10	Connection of a Fatar type piano keyboard
KEYBOARD LOWER PART	J17	2*10	Connection of a Fatar type piano keyboard
FRONT PANEL	J18	2*17	Connection of the dedicated front panel
SPI EXTENSION	J19 (Optional)	1*9	Extension for additional SPI devices
GPIOs	J20 (Optional)	1*6	General purpose I/Os P8[10-9], P8[6-4]
SD SOCKET	J21 (Optional)	WERI 693063010911	SD CARD socket
SD	J22 (Optional, n.m.)	1*9	Connection for external SD CARD socket
8-BIT // LCD Display	J23 (Optional)	1*14	Standard 8-bit LCD connection
USB DEVICE PORT	J24	Mini USB B	USB device, full or high speed connection

"n.m." = not mounted

Jumper Configuration

Reference	Default Setting	Description
JMP4	1-2	Select power supply for panel and keyboard logic: <ul style="list-style-type: none"> • 1-2: VD = +5V • 2-3: VD = +3.3V
JD1	1-2	Quad SPI Flash Chip Select: <ul style="list-style-type: none"> • 1-2: Quad SPI Flash device(s) selected by QNRCS0/ • 2-3: Quad SPI Flash device(s) selected by QNRCS1/
JD2	GND	Keyboard and panel type: <ul style="list-style-type: none"> • Common Anode: GND • Common Cathode: VD33

Layout – Sound Board

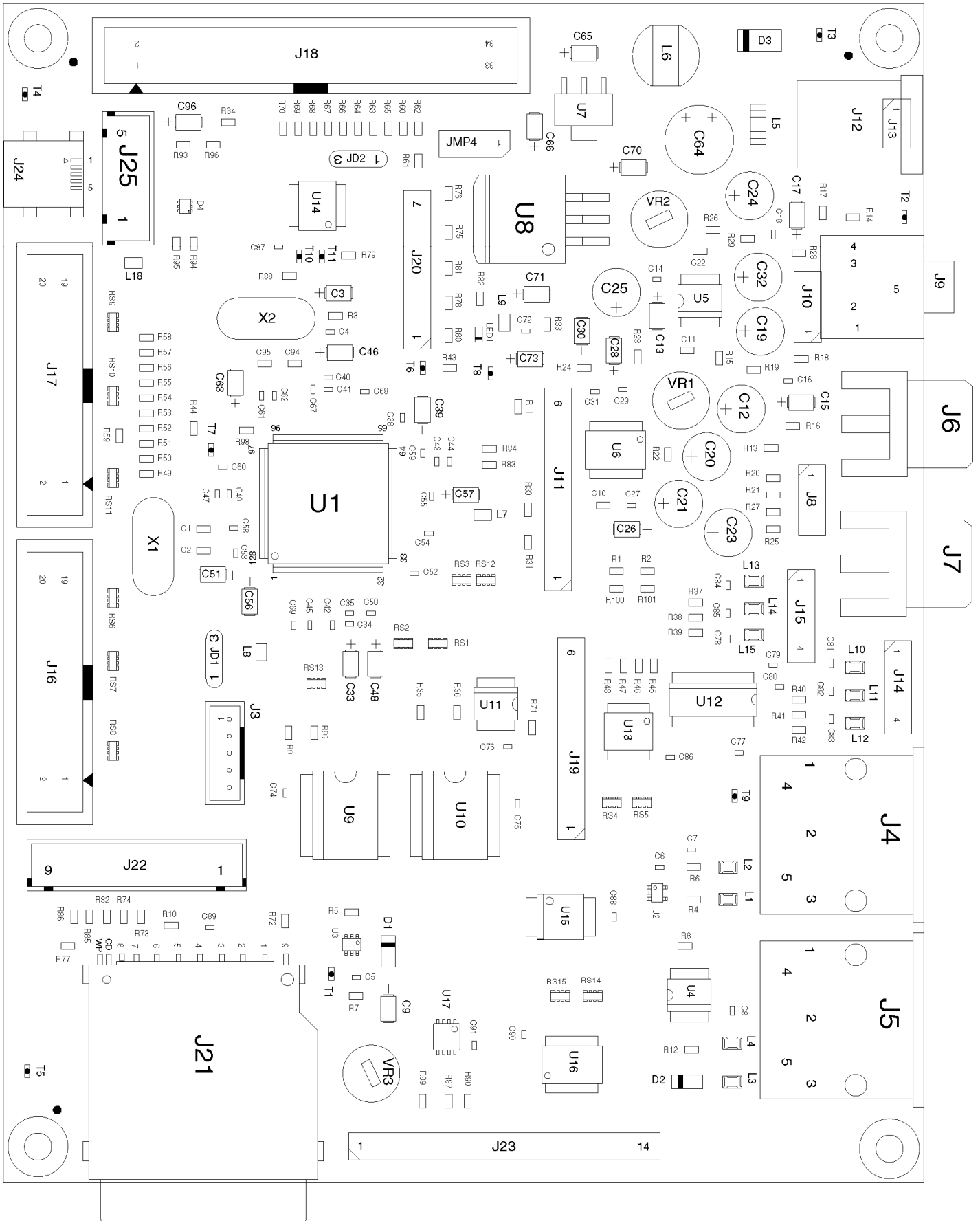

Layout - Front Panel

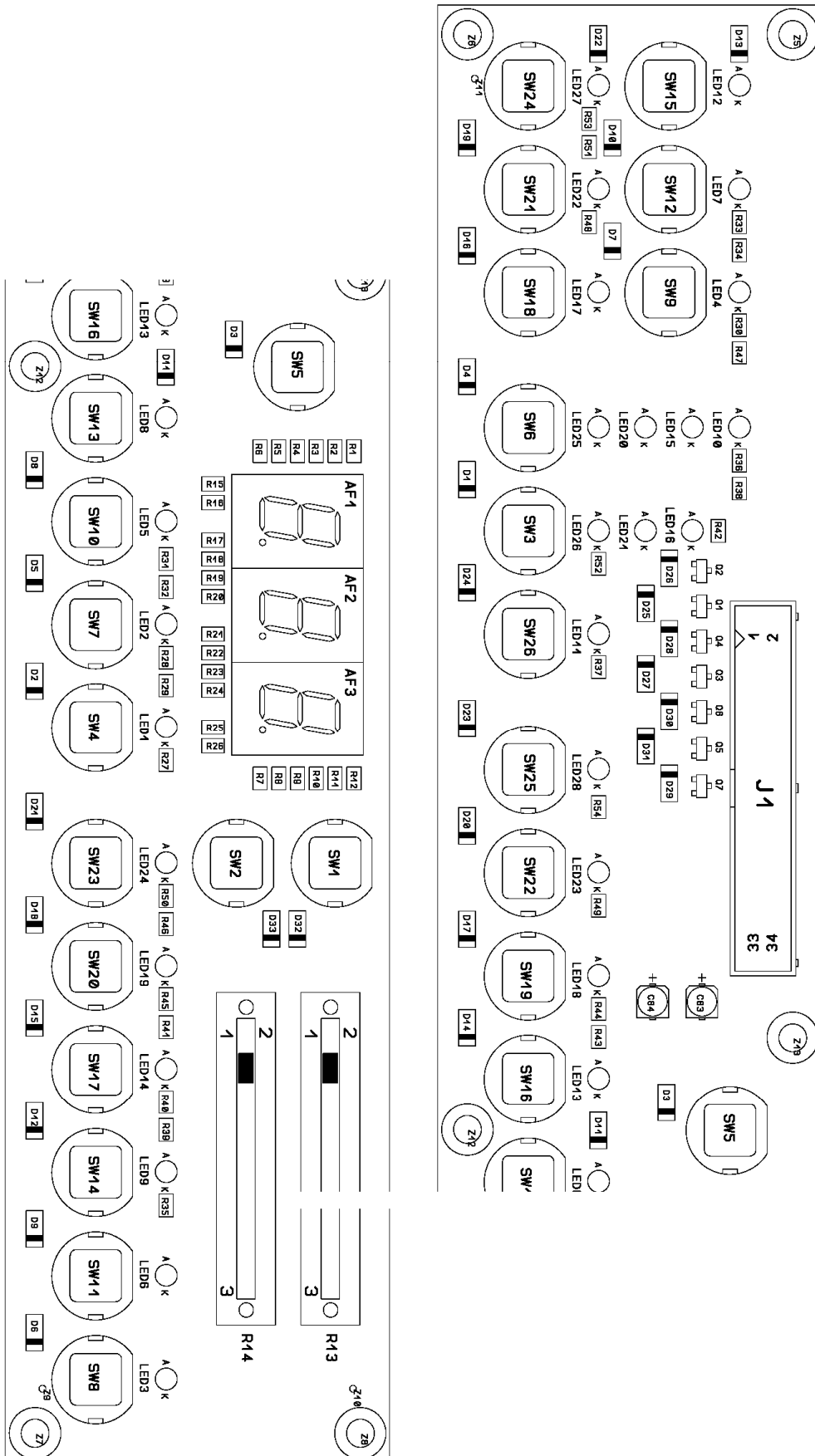

Bill of Material

SAM5704 Development Board - Revised: Thursday, October 14, 2014

5704PIA-DK.DSN Revision: 1

Page 1

Item	Quantity	Reference	Part	Manufacturer	Designation
1	4	C1, C2, C94, C95	22pF		
2	11	C3, C33, C39, C46, C48, C56, C57, C63, C66, C71, C73	10µF-T-10V		
3	46	C4, C5, C6, C7, C8, C14, C16, C18, C27, C29, C31, C34, C38, C40, C43, C45, C47, C50, C53, C54, C58, C59, C60, C61, C67, C68, C69, C72, C74, C75, C76, C77, C78, C79, C80, C81, C82, C83, C84, C85, C86, C87, C88, C89, C90, C91	100nF		
4	2	C9, C51	4.7µF-T-10V		
5	1	C10	470pF		
6	2	C11, C22	100pF		
7	4	C12, C21, C23, C24	10µF-Low Dist	PANASONIC	ECA1HAM100X
8	5	C13, C15, C17, C28, C30	10µF-T-6V		
9	2	C19, C32	2.2µF-Low dist	PANASONIC	ECA1HAK2R2X
10	2	C20, C25	4.7µF-Low dist	PANASONIC	ECA1HAM4R7X
11	1	C26	2.2µF-T-6V		
12	8	C35, C41, C42, C44, C49, C52, C55, C62	10nF		
13	1	C64	470µF-25V		
14	2	C65, C70	10µF-T-16V		
15	1	C96	1µF-T-10V		
16	2	D1, D2	LL4148	VISHAY	LL4148
17	1	D3	1N4002		
18	1	D4	TPD2E1B06	TI	TPD2E1B06
19	1	JD1	Jumper Disk2P		
20	1	JD2	Jumper Disk2P		
21	1	JMP4	Jumper2P	Generic	BA25-Male-7mm-Gold
22	1	J3	B5B-PH-K-S	JST	B5B-PH-K-S
23	2	J4, J5	MIDI_DIN		
24	2	J6, J7	RCA_JACK	3E	10.575N
25	2	J8, J10	N.M.		
26	1	J9	JACK 3.5 STEREO	3E	15.427
27	1	J11	N.M.		

Item	Quantity	Reference	Part	Manufacturer	Designation
28	1	J12	DC PLUG	3E	LD02.02
29	1	J13	N.M.		
30	2	J14, J15	HEAD_4	Generic	BA25-Male-7mm-Gold
31	2	J16, J17	HEAD_10X2		
32	1	J18	HEAD_17X2		
33	1	J19	HEAD_9	Generic	BA25-Male-7mm-Gold
34	1	J20	HEAD_7	Generic	BA25-Male-7mm-Gold
35	1	J21	WERI 693063010911	WURTH	693063010911
36	1	J22	N.M.		
37	1	J23	HEAD_14	Generic	BA25-Male-7mm-Gold
38	1	J24	651 005 161 21	WERI	651 005 161 21
39	1	J25	N.M.	JST	B5B-XH-A
40	1	LED1	TLMS1000-Vishay	VISHAY	TLMS1000-GS08
41	7	L1, L2, L3, L4, L13, L14, L15	NFM21CC102R1H3	MURATA	NFM21CC102R1H
42	1	L5	NFM41PC204F1H3	MURATA	NFM41PC204F1H3
43	1	L6	74477510	WURTH	74477510
44	4	L7, L8, L9, L18	742792093	WURTH	742792093
45	3	L10, L11, L12	NFM21CC102R1H3	MURATA	NFM21CC102R1H3
46	7	RS1, RS2, RS3, RS12, RS13, RS14, RS15	4x10		
47	8	RS4, RS5, RS6, RS7, RS8, RS9, RS10, RS11	4x100		
48	21	R1, R2, R3, R5, R7, R9, R10, R11, R13, R14, R16, R17, R19, R21, R27, R29, R72, R73, R74, R77, R82	10k		
49	5	R4, R6, R12, R20, R25	220		
50	4	R8, R40, R41, R42	4.7k		
51	15	R15, R18, R22, R23, R26, R28, R43, R44, R45, R46, R47, R48, R87, R89, R90	1k		
52	1	R24	5.1		
53	14	R30, R31, R35, R36, R71, R75, R76, R78, R79, R80, R81, R83, R84, R88	10		

Item	Quantity	Reference	Part	Manufacturer	Designation
54	1	R32	750		
55	4	R33, R34, R94, R95	0		
56	5	R37, R38, R39, R96, R99	47k		
57	22	R49, R50, R51, R52, R53, R54, R55, R56, R57, R58, R59, R60, R61, R62, R63, R64, R65, R66, R67, R68, R69, R70	2.2k		
58	3	R85, R86, R93	22k		
59	1	R98	12k, 1%		
60	2	R100, R101	N.M.		
61	11	T1, T2, T3, T4, T5, T6, T7, T8, T9, T10, T11	TestPoint	Vogt	N.M. (985.62 or 1000C.22)
62	1	U1	SAM5704_cfg6	DREAM	SAM5704
63	1	U2	74LVC1G07	TI	74LVC1G07DCK
64	1	U3	74LVC1G57	TI	74LVC1G57DCK
65	1	U4	HCPL-0501		
66	1	U5	OPA2353	BURR-BROWN	OPA2353
67	1	U6	AK4556	AKM	AK4556VT
68	1	U7	LM1117MPX-5.0	NS	LM1117MPX-5.0
69	1	U8	LD1086D2T33 / LD1086D2M33	ST	LD1086D2T33 / LD1086D2M33
70	2	U9, U10	S25FL256SAGMFI001	SPANSION	S25FL256SAGMFI001
71	1	U11	N.M.	MICROCHIP	23LC1024-I/SN
72	1	U12	74HC4051	TI	CD74HC4051
73	2	U13, U14	74HC238	TI	74HC238PW
74	1	U15	AT45DB041E-SHN	ADESTO	AT45DB041E-SHN
75	1	U16	74AHCT245	TI	74AHCT245PW
76	1	U17	74LVC3G07	TI	74LVC3G07DCU
77	2	VR1, VR2	50k	BOURNS	POT-3329H
78	1	VR3	20k	BOURNS	POT-3329H-203
79	1	X1	PQ18	FISCHER	PQ18
80	1	X2	12 MHz		

FRONT PANEL - DIGITAL PIANO Revised: Friday, August 11, 2006
 5700PIFP-DK.SCH Revision: 0
 Bill Of Materials August 11,2006 Page1

Item	Quantity	Reference	Part
1	3	AF1, AF2, AF3	HDSP-5551
2	2	C83, C84	10µF-A-16V
3	33	D1, D2, D3, D4, D5, D6, D7, D8, D9, D10, D11, D12, D13, D14, D15, D16, D17, D18, D19, D20, D21, D22, D23, D24, D25, D26, D27, D28, D29, D30, D31, D32, D33	LL43
4	2	JD1, JD2	SOLDER PAD
5	1	J1	HEAD_17X2
6	28	LED1, LED2, LED3, LED4, LED5, LED6, LED7, LED8, LED9, LED10, LED11, LED12, LED13, LED14, LED15, LED16, LED17, LED18, LED19, LED20, LED21, LED22, LED23, LED24, LED25, LED26, LED27, LED28	TLHR4400
7	7	Q1, Q2, Q3, Q4, Q5, Q6, Q7	MMBT2222A
8	52	R1, R2, R3, R4, R5, R6, R7, R8, R9, R10, R11, R12, R15, R16, R17, R18, R19, R20, R21, R22, R23, R24, R25, R26, R27, R28, R29, R30, R31, R32, R33, R34, R35, R36, R37, R38, R39, R40, R41, R42, R43, R44, R45, R46, R47, R48, R49, R50, R51, R52, R53, R54	100
9	2	R13, R14	STRS30101
10	26	SW1, SW2, SW3, SW4, SW5, SW6, SW7, SW8, SW9, SW10, SW11, SW12, SW13, SW14, SW15, SW16, SW17, SW18, SW19, SW20, SW21, SW22, SW23, SW24, SW25, SW26	SW_PUSH

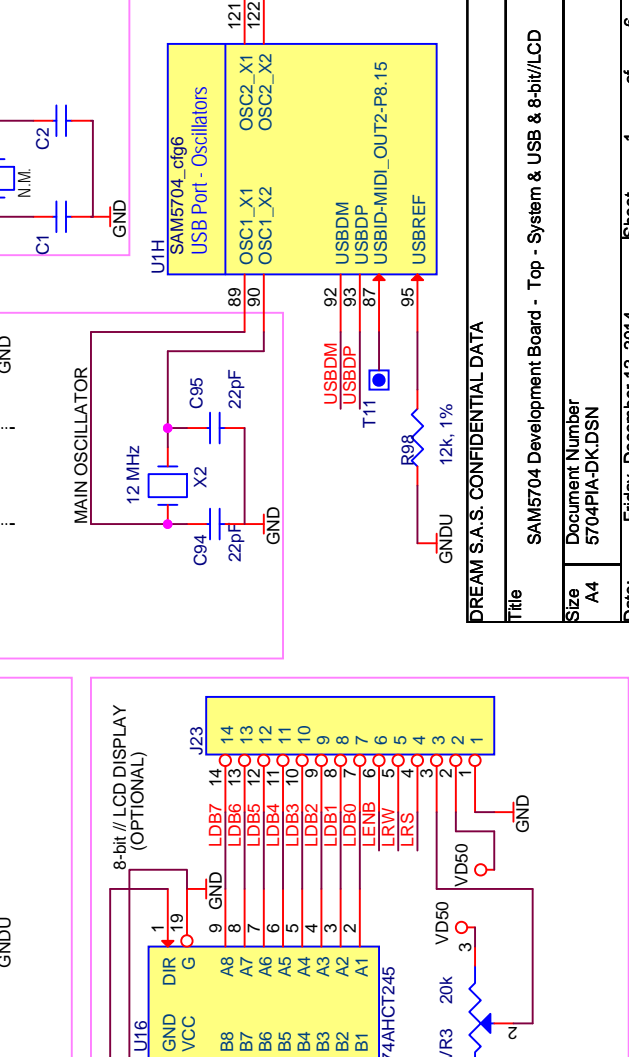
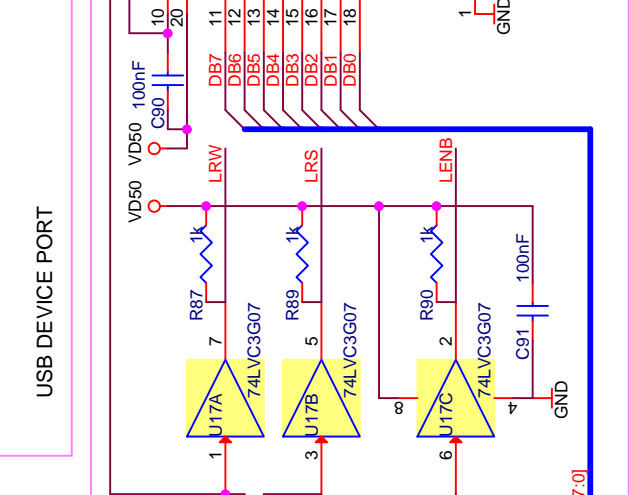
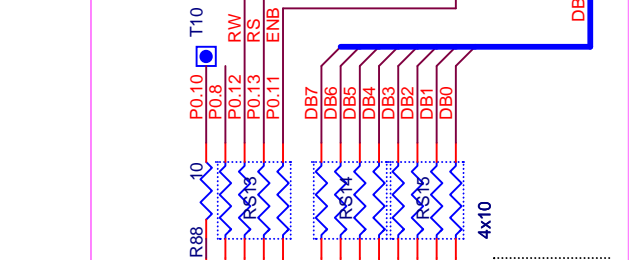
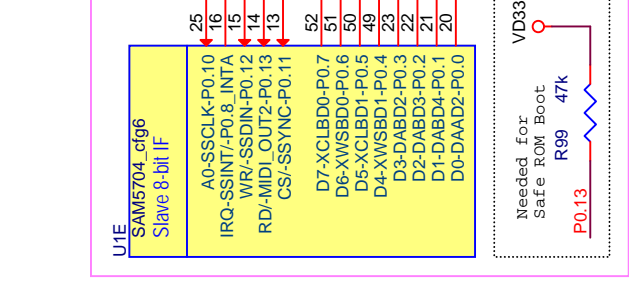
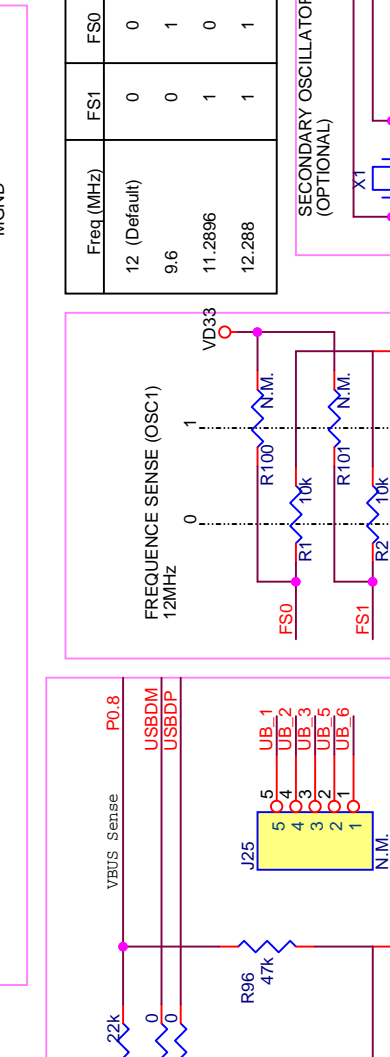
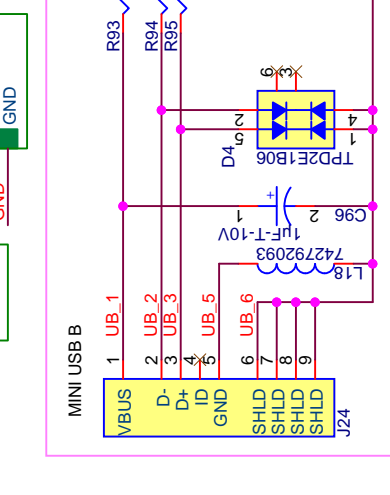
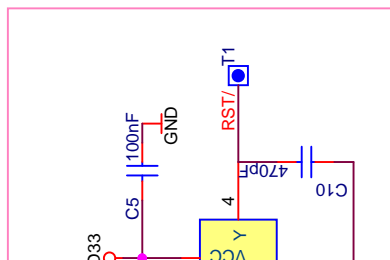
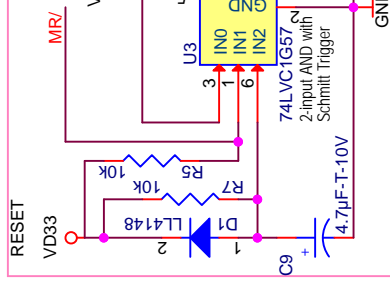
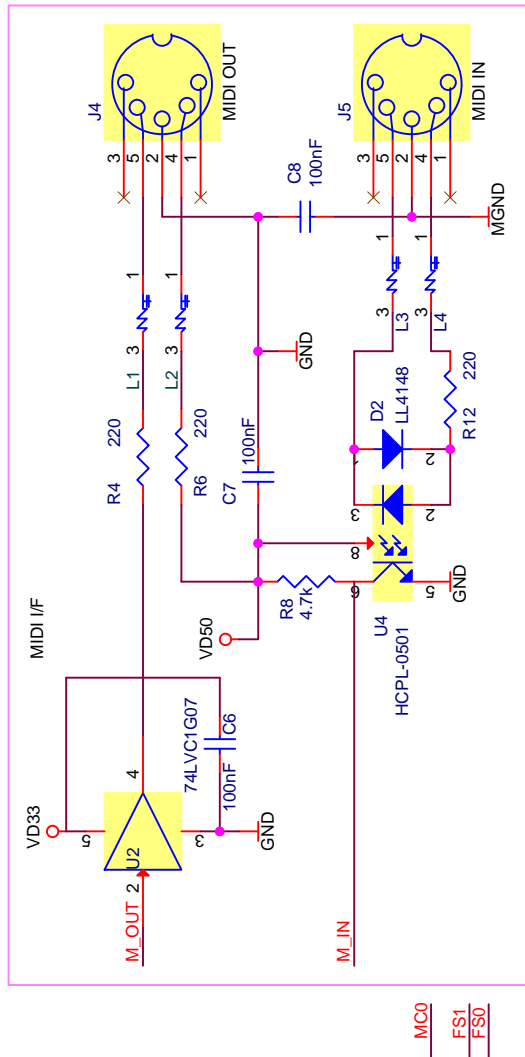
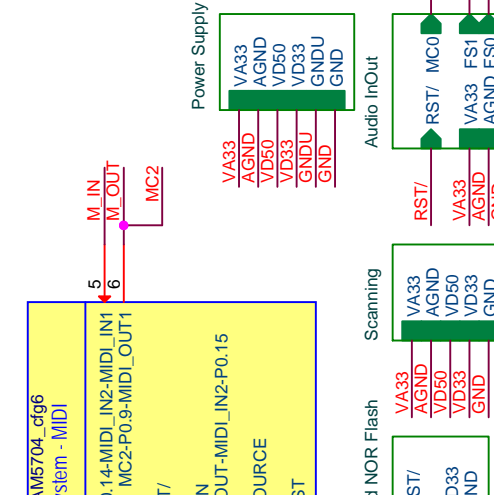
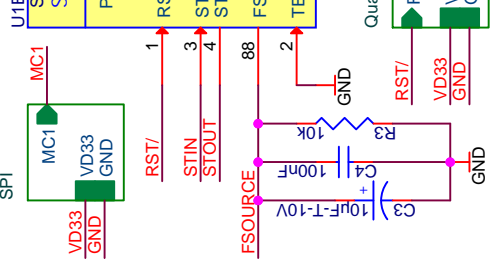
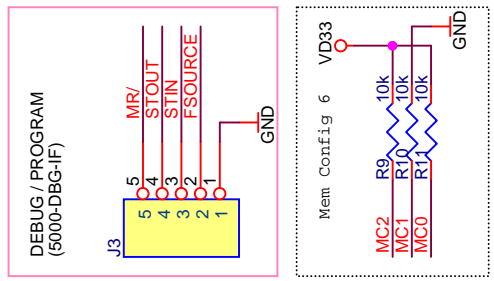

Freq. (MHz)	FS0	FS1	FS0
12 (Default)	0	0	0
9.6	0	0	1
11.2896	1	0	0
12.288	1	1	1

DREAM S.A.S. CONFIDENTIAL DATA

Title SAM5704 Development Board - Top - System & USB & 8-bit/LCD

Size A4 Document Number 5704PIA-DK.DSN

Date: Friday, December 12, 2014 Sheet 1 of 6

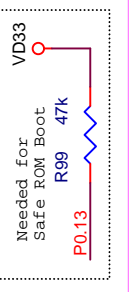

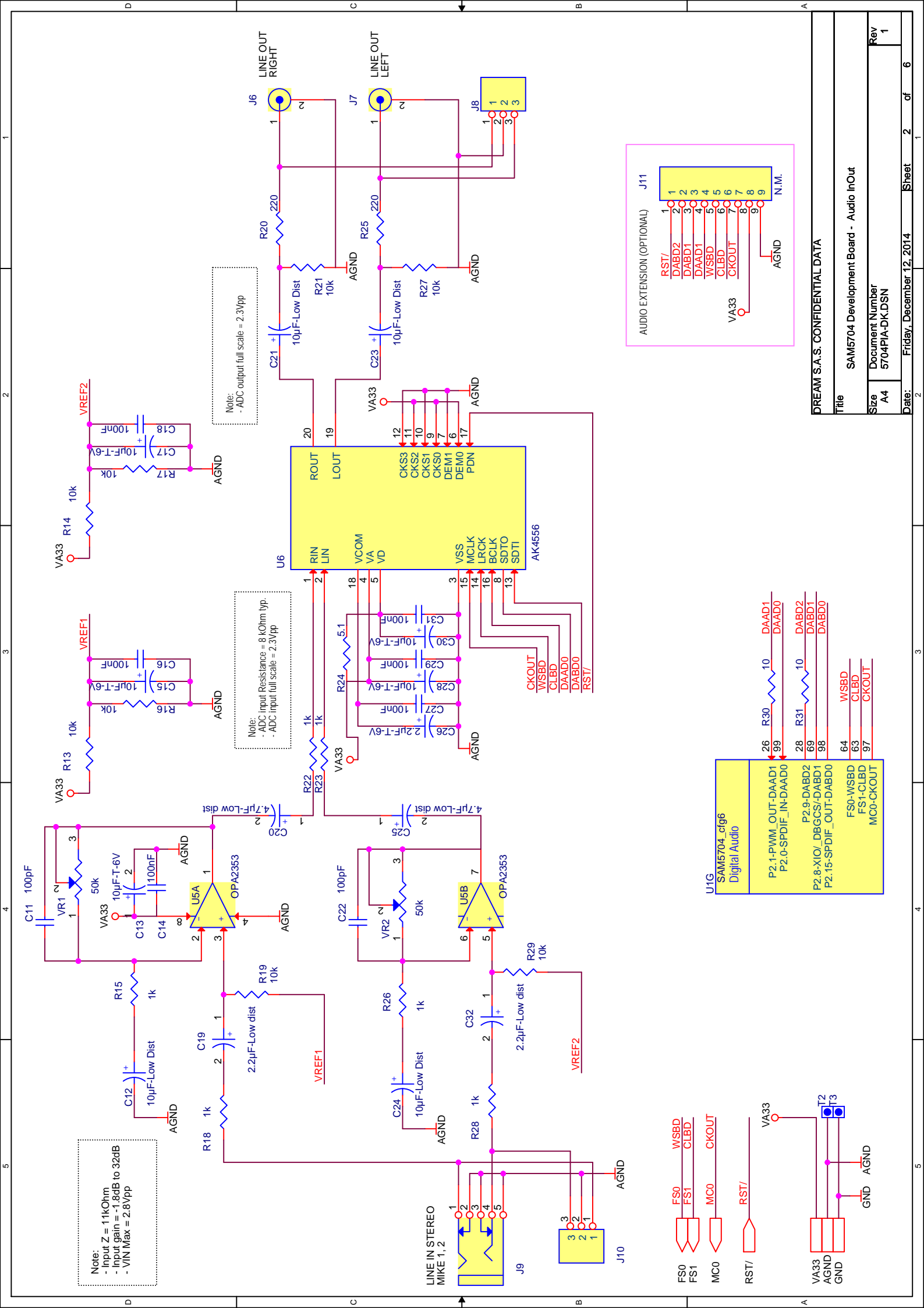

DREAM S.A.S. CONFIDENTIAL DATA

Title SAM5704 Development Board - Audio InOut

Size A4 Document Number 5704PIA-DKDSN Rev 1

Date: Friday, December 12, 2014 Sheet 2 of 6

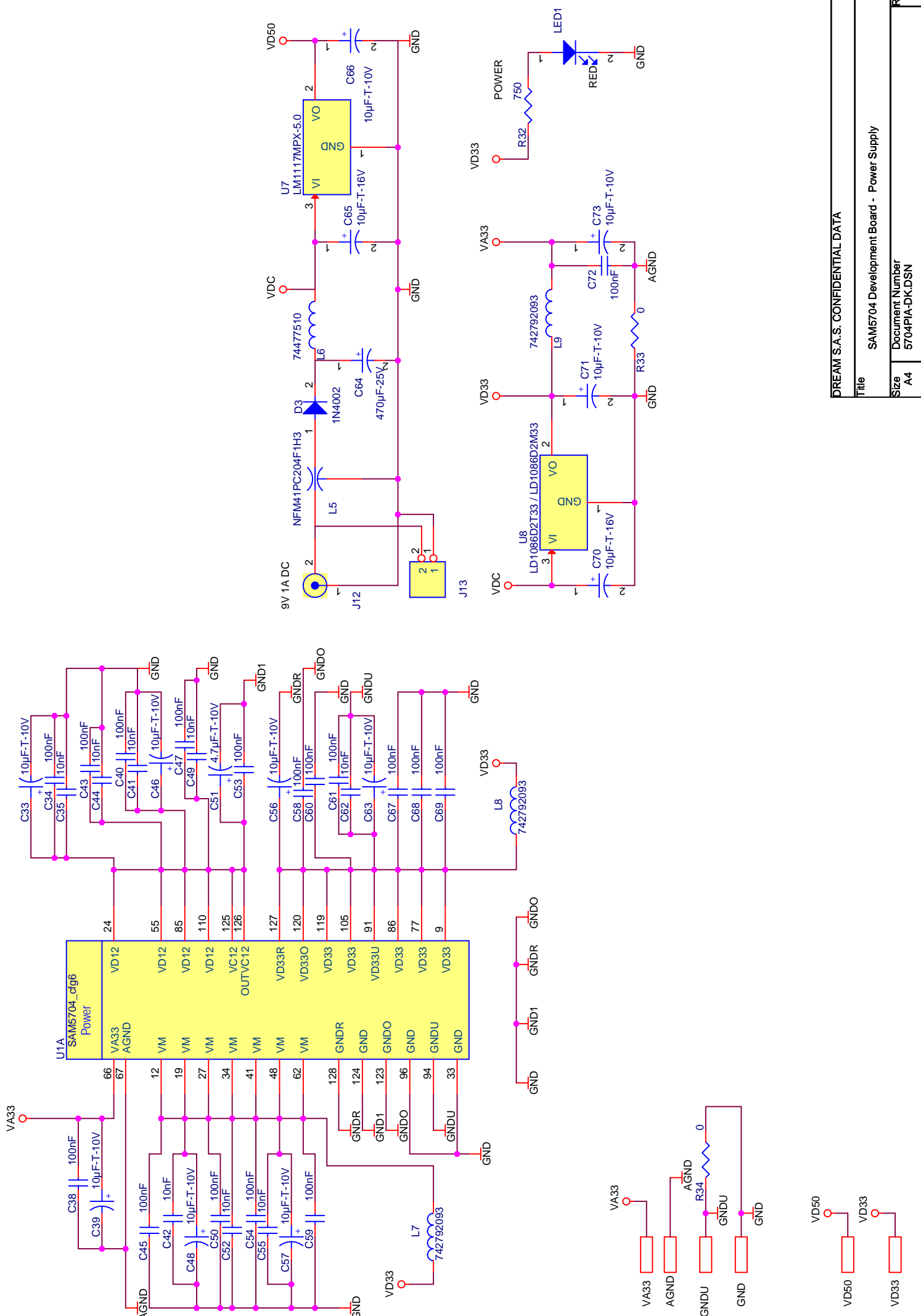

DREAM S.A.S. CONFIDENTIAL DATA

Title		SAM5704 Development Board - Power Supply	
Size	A4	Document Number	5704PIA-DKDSN
Date:	Friday, December 12, 2014	Sheet	3 of 6

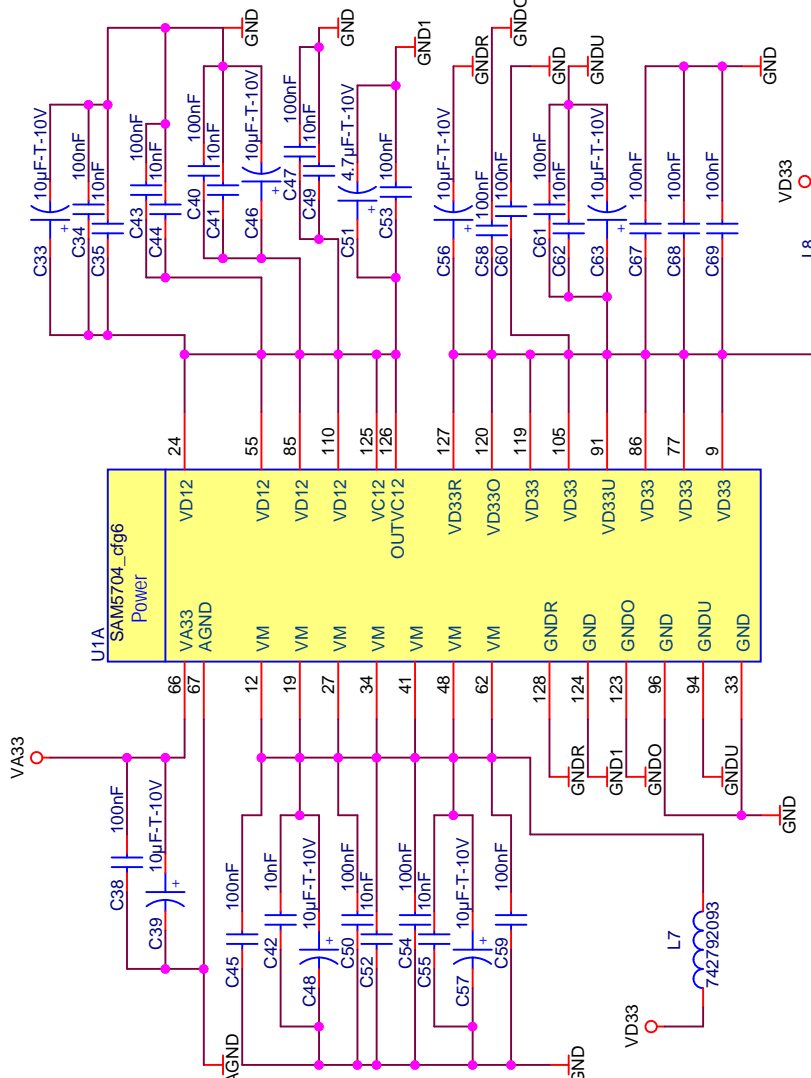
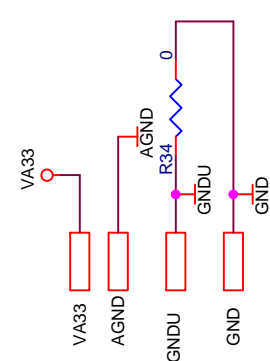
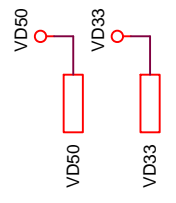

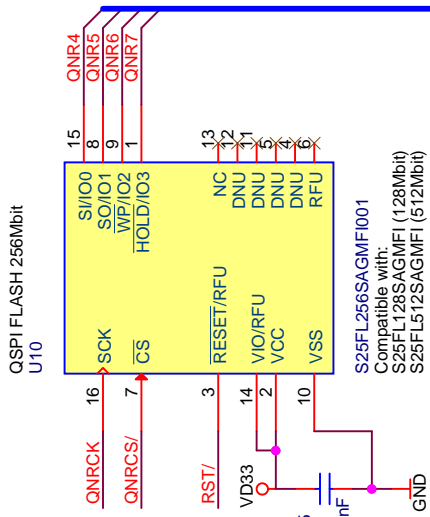
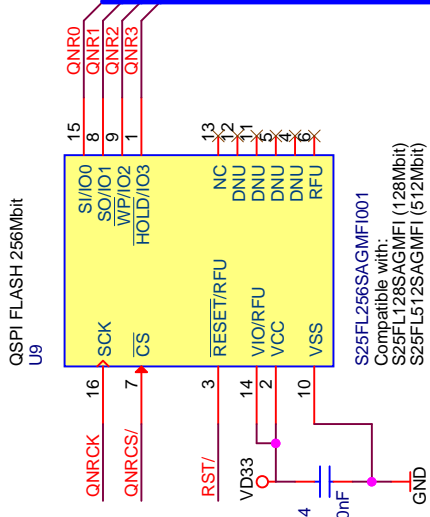
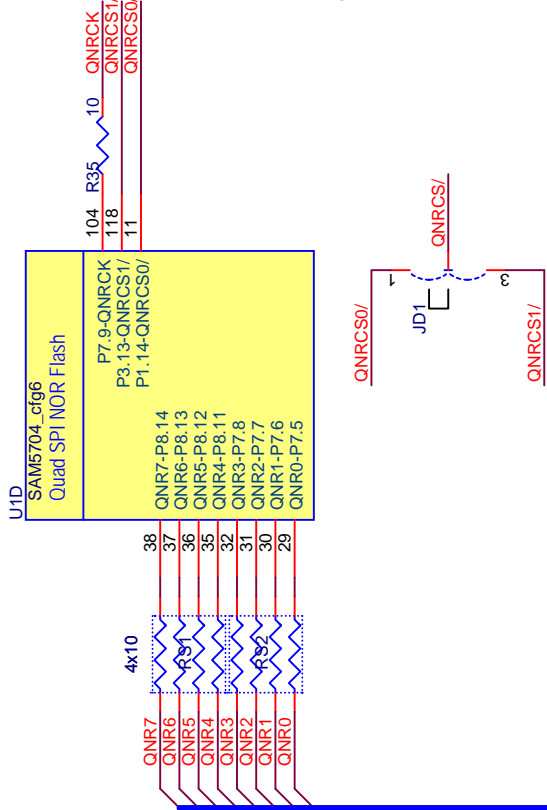

OPTIONAL for OCTAL SPI Mode

QNR[7:0]

OPTIONAL QUAD SPI SRAM
NOT USED FOR STANDARD PIANO OR KEYBOARD APPLICATION

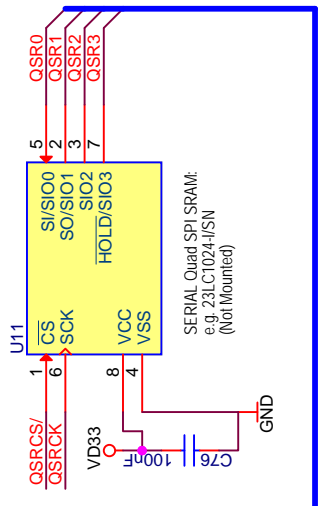
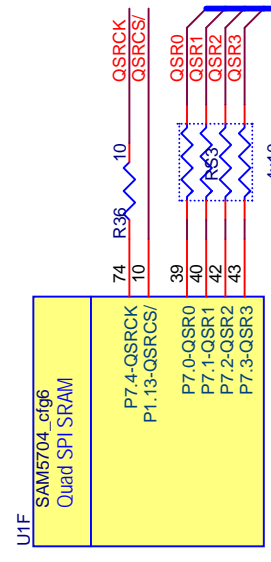

QSR[3:0]

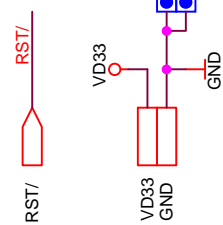

DREAM S.A.S. CONFIDENTIAL DATA

Title		SAM5704 Development Board - Quad NOR Flash	
Size	Document Number	Date	Rev
A4	5704PIA-DKDSN	Friday, December 12, 2014	1
Sheet		4	of 6

NOTES:

- COMMON ANODE MODE:
 - JD1 = On, JD2 = Off
 - All transistors are MMBT2222A (NPN)
 - LED displays are HDSP-5551
 - All diodes and LEDs as shown
- COMMON CATHODE MODE:
 - JD1 = Off, JD2 = On
 - All transistors are MMBT2907A (PNP)
 - LED displays are HDSP-5553
 - All diodes and LEDs are inverted

ALL RESISTORS = 100 ohm
 ALL DIODES = 1N4148
 ALL LEDs = TLHR4400

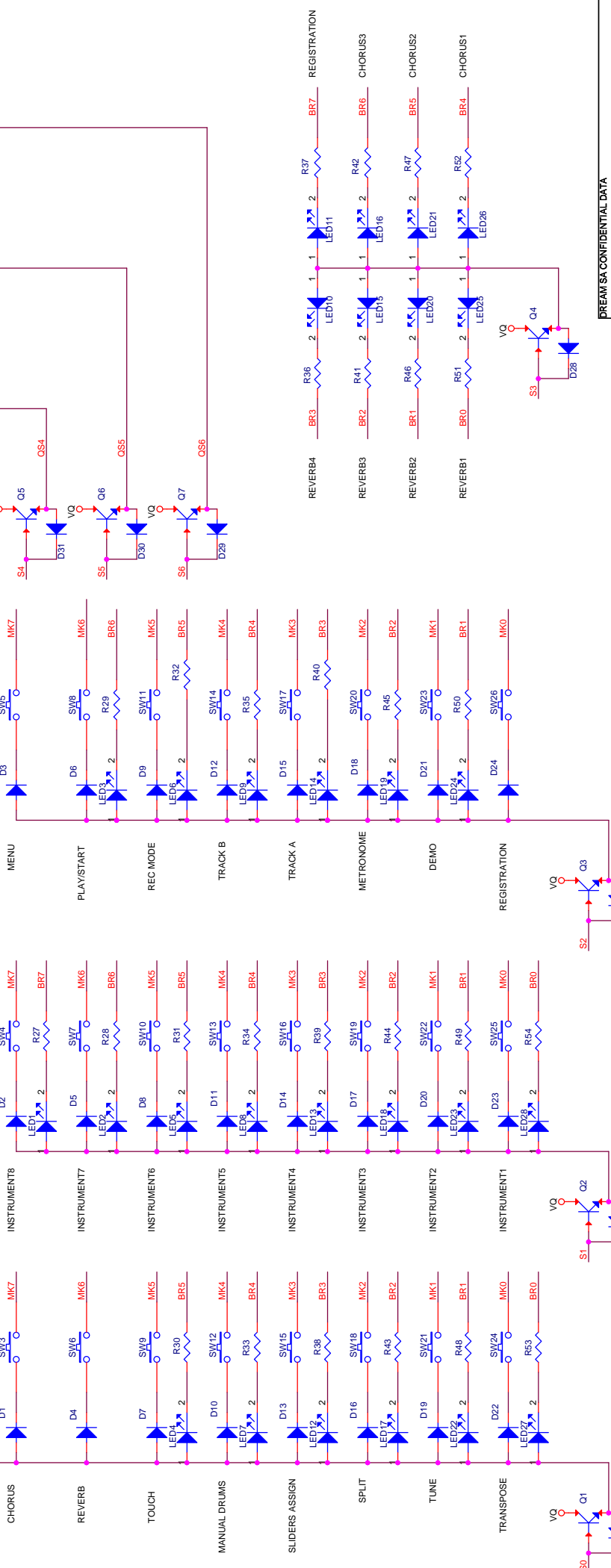
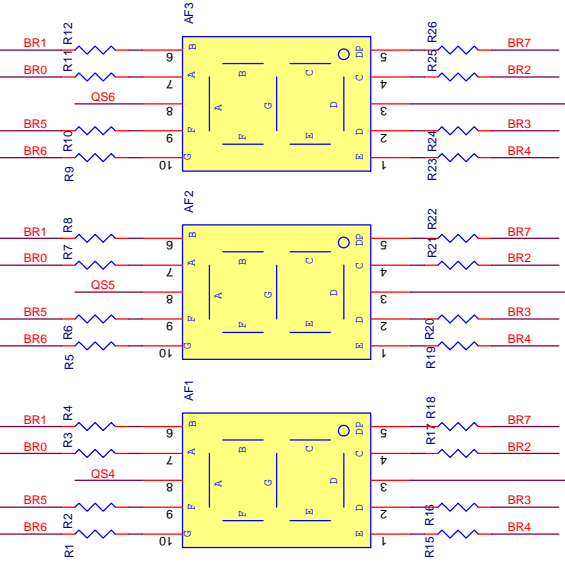
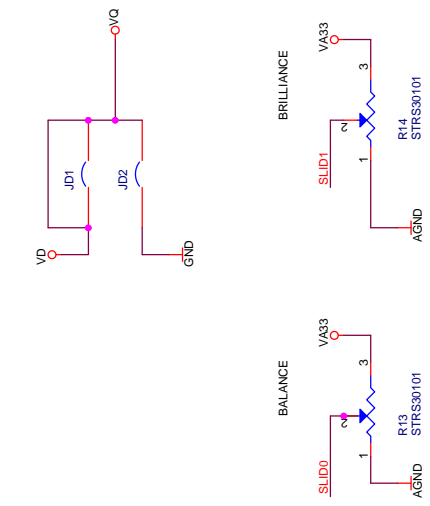
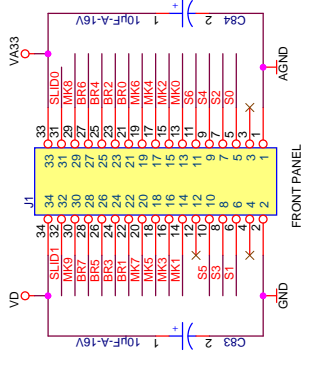

DRAWING IS CONFIDENTIAL DATA

Title		FRONT PANEL - DIGITAL PIANO	
Size	A3	Document Number	5700PIF-DK-SCH
Date:	Wednesday, July 05, 2017	Sheet	1 of 1
Rev	0.1		

Dream Contact

info@dream.fr

Website

<http://www.dream.fr>

*This publication neither states nor implies any warranty of any kind, including, but not limited to, implied warrants of merchantability or fitness for a particular application. Dream assumes no responsibility for the use of any circuitry. No circuit patent licenses are implied.
The information in this publication is believed to be accurate in all respects at the time of publication but is subject to change without notice. Dream assumes no responsibility for errors and omissions, and disclaims responsibility for any consequences resulting from the information included herein.*