

## Overview

5916PIA2-DK is a high quality stand-alone development and reference board based on SAM5916 (AUDIO & MUSIC MULTI-DSP PROCESSOR) dedicated to digital piano and keyboard instruments. The SAM5916 can be used in 6 different hardware configurations for different applications. On 5916PIA2-DK board the SAM5916 is running in the hardware configuration dedicated to Piano applications with firmware and sound bank stored in NAND Flash, sample cache and extended delay lines in SDRAM.

Beside the SAM5916 the 5916PIA2-DK hardware includes:

- 1 x Audio DAC: AKM AK4490EQ (120dB DR, -112dB THD+N)
- 1 Audio ADC AKM AK5386VT (24-bit, DR:110dB, S/(N+D):96dB)
- 2 x 8Gbit NAND Flash MICRON MT29F8G16ABACAWP (2Gbyte)
- 256Mbit SDRAM: WINBOND W9825G6KH-6
- DataFlash® memory ADESTO AT45DB081E (8Mbit) for firmware, sequencer and data storage.
- USB High Speed Device Port
- USB High Speed Host Port

## Dream NAND Flash Solution

DREAM NAND Flash solution allows the storage of large sound banks in cost-effective NAND Flash memory devices. Thanks to its sophisticated sample cache system, the SAM5916 offers high performances, security and reliability:

- Support SLC NAND Flash technology (up to 8GByte)
- High polyphony: up to 256 voices + effects
- Transparent pages transfer from NAND to SDRAM buffers
- Automatic error correction (ECC)
- Bad block management and wear leveling ensuring NAND Flash lifetime
- AES-protected sound banks with on-the-fly decryption
- Sound bank compiler for NAND Flash technology

## Hardware Configuration

5916PIA2-DK is designed to be connected to an 88-note velocity sensitive piano keyboard with 3 contacts per key (e.g., FATAR TP40M, 3-contact).

The 5916PIA-C-PDK reference design kit includes the 5916PIFP-DK front panel.

## Operating Modes

5916PIA2-DK operates on two modes:

- **Debug/Program mode:**

The board is connected to a PC through the Dream 5000DBG-IF adaptor. Firmware can be downloaded and debugged into internal RAM or external SDRAM with Dream SamVS-C development software. With SamVS or ProgSam software tool it is possible to program the firmware into NAND Flash memory or serial DataFlash memory for stand-alone mode. The sound bank can be loaded into NAND Flash memory from a USB stick. With ProgSam tool it is also possible to program the eFuses on SAM5916 for encryption / copy protection of firmware code and sound bank content.
- **Stand-alone mode:**

In this mode the SAM5916 loads the program from the NAND Flash or serial DataFlash into RAM (internal RAM + external SDRAM) at startup, then executes it in RAM and scans the front panel and the piano keyboard.

## Connectors Configuration

Name	Reference	Type	Description
DEBUG / PROGRAM	J1	JST PH Series, 1*5	Serial connection for debug and program, compatible with Dream 5000DBG-IF
MIDI OUT	J2	5-pin Din	Standard MIDI OUT at 31.25kb/s
MIDI IN	J3	5-pin Din	Standard MIDI IN at 31.25kb/s
	J4 (Optional, n.m.)	1*5	Connection to external MIDI IN an OUT connectors
HEADPHONES DETECT	J5	1*2	Headphones detection
SPI LCD	J6	JST XH Series, 1*10	SPI connection to a Graphic LCD Display
GPIOs	J7	1*6	General purpose I/Os P3.7, P5[11:9]
PEDALS INPUT	J8	1*4	Connection for pedals (analog inputs)
SLIDERS INPUT	J9 (Optional, n.m.)	1*4	Connection for analog potentiometers
LINE OUT L	J10	RCA	Left Main audio line output (1.5V RMS)
LINE OUT R	J11	RCA	Right Main audio line output (1.5V RMS)
	J12 (Optional, n.m.)	1*3	Stereo Main audio line output (1.5V RMS)
AUDIO IN STEREO	J13	Mini Jack	Stereo audio input(0.02 to 1V RMS)
	J14 (Optional, n.m.)	1*3	Stereo audio input(0.02 to 1V RMS)
KEYBOARD LOWER PART	J15	FFC, 1mm, 22way	Connection of a Fatar type piano keyboard. e.g. TP40M, 3-contact
KEYBOARD HIGHER PART	J16	FFC, 1mm, 20way	Connection of a Fatar type piano keyboard. e.g. TP40M, 3-contact
FRONT PANEL	J17	HE10 - 2*17	Connection of the dedicated front panel
9 / 12 V DC	J18	DC Plug	Power Supply, +9V...12V/1A, minus on tip
	J19 (Optional, n.m.)	1*2	Power Supply, +9V...12V/1A
USB DEVICE	J20	USB B	USB Device, full or high speed port.
	J21 (Optional, n.m.)	JST XH Series, 1*5	USB Device, full or high speed port.
USB HOST	J22	USB A	USB Host, full or high speed port.
	J23 (Optional, n.m.)	JST XH Series, 1*5	USB Host, full or high speed port.

“n.m.” = not mounted

## Jumper Configuration

Reference	Default Setting	Description
JMP1	Closed	For test and measurements on VA33
JMP2	Closed	For test and measurements on VD33
JMP3	Closed	For test and measurements on VA50
JMP4	Closed	For test and measurements on VD50
JD1	2-3	Select Digital audio source for Main audio out. <ul style="list-style-type: none"> <li>• 2-3: DABD2</li> <li>• 1-2: DABD0 (cannot be used while SPDIF OUT is needed)</li> </ul>

Layout - Top side

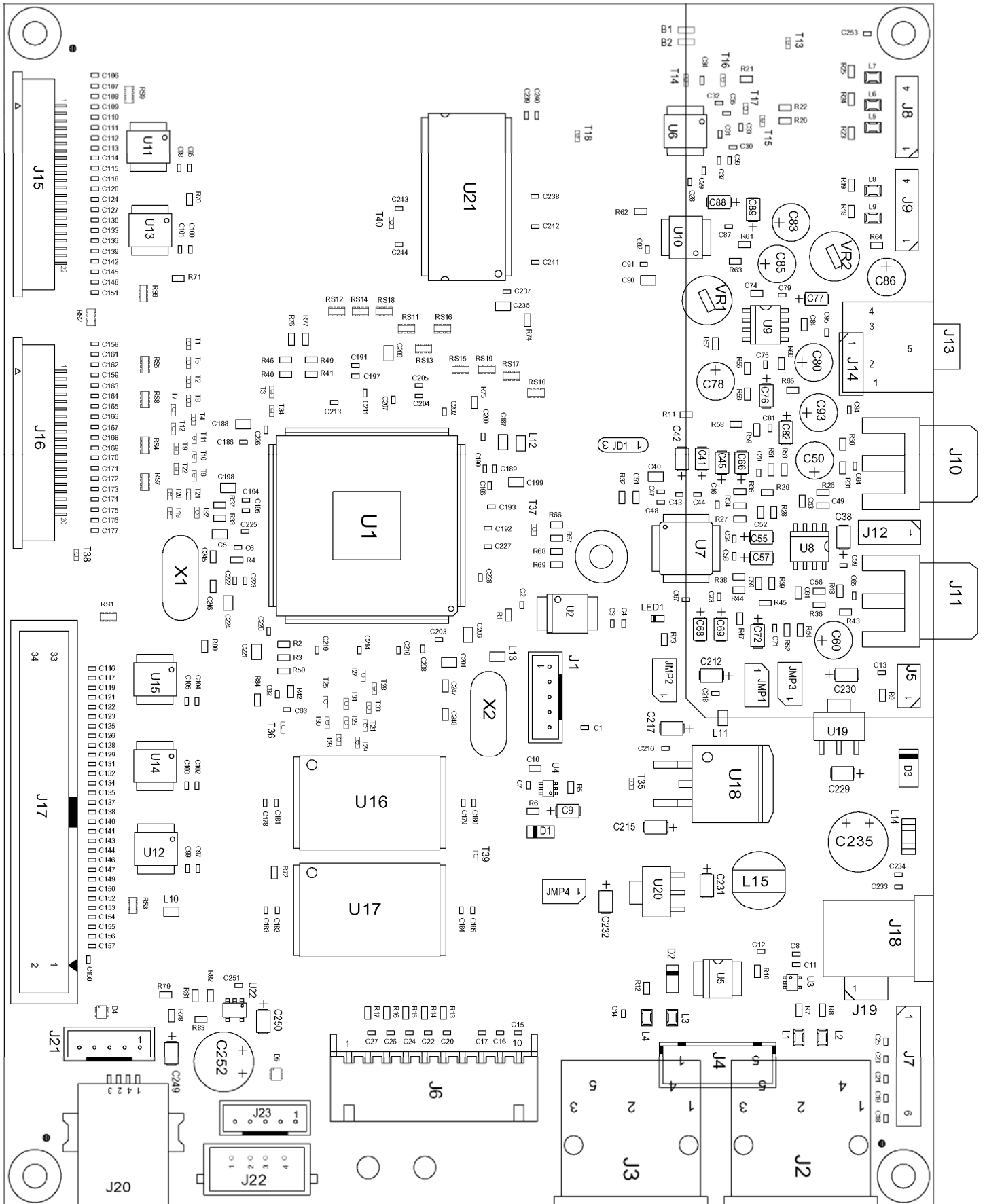

Bill of Material

SAM5916 - PIANO BOARD - Revised: March 10, 2017

5916PIA2-DK.DSN Revision: 0.1

Page 1

Item	Quantity	Reference	Part	Manufacturer	Designation
1	2	B1, B2	BRIDGE		
2	83	C1, C3, C11, C13, C15, C16, C17, C18, C19, C21, C23, C25, C37, C48, C92, C94, C95, C98, C99, C101, C103, C105, C160, C181, C184, C190, C204, C211, C214, C223, C228, C234, C237, C239	470pF		
3	8	C2, C62, C63, C64, C65, C180, C183, C233	N.M.		
4	67	C4, C6, C7, C8, C12, C14, C28, C29, C30, C31, C32, C33, C34, C35, C36, C39, C43, C44, C46, C47, C54, C58, C67, C70, C71, C73, C75, C79, C81, C87, C91, C96, C97, C100, C102, C104, C178, C179, C182, C185, C186, C189, C191, C192, C194, C196, C200, C202, C203, C207, C208, C210, C213, C216, C218, C219, C222, C225, C226, C227, C238, C240, C241, C242, C243, C244, C251	100nF		
5	12	C5, C40, C90, C187, C188, C198, C199, C206, C209, C221, C224, C236	10µF-16V		
6	2	C9, C89	4.7µF-T-10V		
7	6	C10, C49, C51, C53, C56, C61	470pF		
8	5	C20, C22, C24, C26, C27	47pF		
9	15	C38, C42, C45, C55, C57, C69, C76, C77, C82, C88, C212, C217, C230, C232, C250	10µF-T-10V		
10	2	C41, C68	100µF-T-10V		
11	4	C50, C60, C78, C86	10µF-Low Dist	PANASONIC	ECA1HAM100X
12	2	C52, C59	1nF		
13	2	C66, C72	47µF-T-6V		
14	2	C74, C84, C106, C108, C114, C117, C121, C123, C124, C126, C129, C135, C136, C138, C141, C150, C153, C155, C161, C163, C166, C169, C172, C177,	100pF		

Item	Quantity	Reference	Part	Manufacturer	Designation
15	2	C80, C93	2.2µF-Low dist	PANASONIC	ECA1HAK2R2X
16	2	C83, C85	4.7µF-Low dist	PANASONIC	ECA1HAM4R7X
17	23	C107, C109, C110, C111, C112, C113, C115, C116, C118, C119, C120, C122, C125, C127, C128, C130, C131, C132, C133, C134, C137, C139, C140, C142, C143, C144, C145, C146, C147, C148, C149, C151, C152, C154, C156, C157, C158, C159, C162, C164, C165, C167, C168, C170, C171, C173, C174, C175, C176, C253	220pF		
18	5	C193, C195, C197, C205, C220	10nF		
19	1	C201	4.7µF-16V		
20	3	C215, C229, C231	10µF-T-16V		
21	1	C235	470µF-25V		
22	4	C245, C246, C247, C248	22pF		
23	1	C249	1µF-T		
24	1	C252	150µF		
25	2	D1, D2	LL4148	VISHAY	LL4148
26	1	D3	1N4002		
27	2	D4, D5	TPD2E1B06	TI	TPD2E1B06
28	5	H1, H2, H3, H4, H5	Fixing_Hole		
29	1	JD1	Jumper Disk2P		
30	4	JMP1, JMP2, JMP3, JMP4	Jumper1P	Generic	BA25-Male-7mm-Gold
31	1	J1	B5B-PH-K-S	JST	B5B-PH-K-S
32	2	J2, J3	MIDI_DIN		
33	1	J4	N.M.	JST	B5B-XH-A
34	1	J5	HEAD_2	Generic	BA25-Male-7mm-Gold
35	1	J6	S10B-XH-A	JST	S10B-XH-A
36	1	J7	HEAD_6	Generic	BA25-Male-7mm-Gold
37	1	J8	HEAD_4	Generic	BA25-Male-7mm-Gold
38	1	J9	N.M.	Generic	BA25-Male-7mm-Gold
39	2	J10, J11	RCA_JACK	3E	10.575N
40	2	J12, J14	N.M.		
41	1	J13	JACK 3.5 STEREO	3E	15.427

Item	Quantity	Reference	Part	Manufacturer	Designation
42	1	J15	AMP-2-84952-2	TYCO ELECTRONICS	AMP- 2-84952-2
43	1	J16	AMP- 2-84952-0	TYCO ELECTRONICS	AMP- 2-84952-0
44	1	J17	HEAD_17X2_Splitted		
45	1	J18	DC PLUG	3E	LD02.02
46	1	J19	N.M.		
47	1	J20	WERI 62910416121	WERI	WERI 62910416121
48	2	J21, J23	N.M.	JST	B5B-PH-K-S
49	1	J22	WERI 614004185023	WERI	WERI 614004185023
50	1	LED1	TLMS1000-Vishay	VISHAY	TLMS1000-GS08
51	9	L1, L2, L3, L4, L5, L6, L7, L8, L9	NFM21CC102R1H3	MURATA	NFM21CC102R1H
52	1	L10	742792093	WURTH	742792093
53	2	L11, L12	742792093	WURTH	742792093
54	1	L13	7427920415	WURTH	7427920415
55	1	L14	NFM41PC204F1H3	MURATA	NFM41PC204F1H3
56	1	L15	74477510	WURTH	74477510
57	9	RS1, RS2, RS3, RS4, RS5, RS6, RS7, RS8, RS9	4x2.2k		
58	10	RS10, RS11, RS12, RS13, RS14, RS15, RS16, RS17, RS18, RS19	4x33		
59	17	R1, R2, R4, R5, R6, R9, R31, R48, R55, R56, R58, R59, R60, R65, R76, R77, R81	10k		
60	1	R3	N.M.		
61	5	R7, R8, R12, R30, R43	220		
62	9	R10, R23, R24, R25, R51, R52, R53, R54, R72	4.7k		
63	3	R11, R78, R83	22k		
64	5	R13, R14, R15, R16, R17	100		
65	5	R18, R19, R20, R21, R22	1M		
66	4	R26, R35, R36, R47	3k		
67	4	R27, R34, R38, R44	3.9k		
68	4	R28, R29, R39, R45	3.6k		
69	1	R32	22		
70	9	R33, R37, R40, R41, R42, R46, R49, R50, R62	33		
71	8	R57, R64, R66, R67, R68, R69, R70, R71	1k		
72	2	R61, R63	0		

Item	Quantity	Reference	Part	Manufacturer	Designation
73	1	R73	750		
74	2	R74, R75	33		
75	2	R79, R82	47k		
76	2	R80, R84	12k, 1%		
77	40	T1, T2, T3, T4, T5, T6, T7, T8, T9, T10, T11, T12, T13, T14, T15, T16, T17, T18, T19, T20, T21, T22, T23, T24, T25, T26, T27, T28, T29, T30, T31, T32, T33, T34, T35, T36, T37, T38, T39, T40	TestPoint	Vogt	N.M. (985.62 or 1000C.22)
78	1	U1	SAM5916_Cfg3	DREAM	SAM5916B
79	1	U2	AT45DB081E-SHN	ADESTO	AT45DB081E-SHN
80	1	U3	74LVC1G07	TI	74LVC1G07DCK
81	1	U4	74LVC1G57	TI	74LVC1G57DCK
82	1	U5	HCPL-0501		
83	1	U6	74HC4051	TI	CD74HC4051PW
84	1	U7	AK4490EQ		
85	1	U8	OPA2353	TI	OPA2353
86	1	U9	OPA2353	BURR-BROWN	OPA2353
87	1	U10	AK5386VT	AKM	AK5386VT
88	2	U11, U12	74HC238	TI	74HC238PW
89	3	U13, U14, U15	74HC257	TI	74HC257PW
90	2	U16, U17	MT29F8G16ABACAWP	MICRON	MT29F8G16ABACAWP
91	1	U18	LD1086D2T33	ST	LD1086D2T33
92	2	U19, U20	LM1117MPX-5.0	NS	LM1117MPX-5.0
93	1	U21	MT48LC16M16A2P-7E W9825G6KH-6	MICRON WINBOND	MT48LC16M16A2P-7E W9825G6KH-6
94	1	U22	MIC2005A-1YM5	MICREL	MIC2005A-1YM5
95	2	VR1, VR2	50k	BOURNS	POT-3329H
96	1	X1	12 MHz		
97	1	X2	12.288 MHz + socket	FISCHER	PQ18



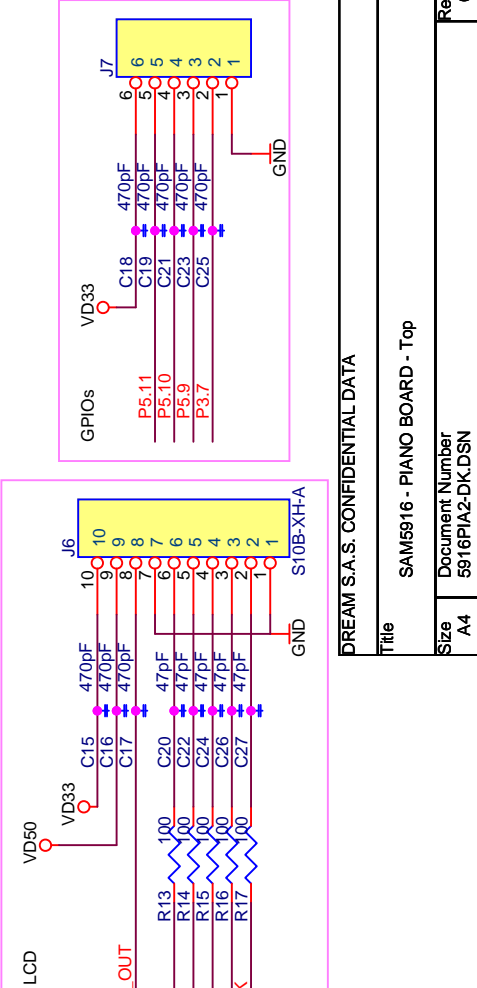
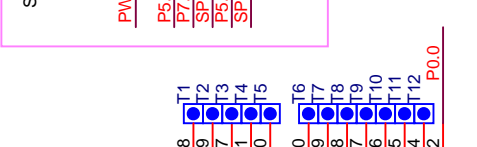
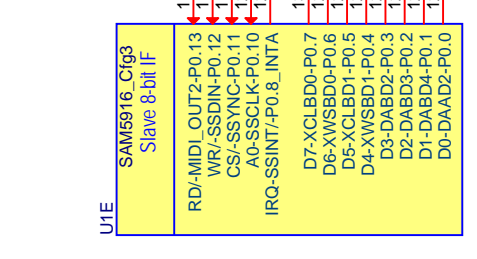
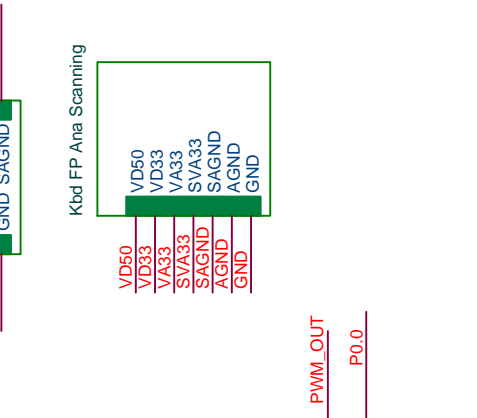
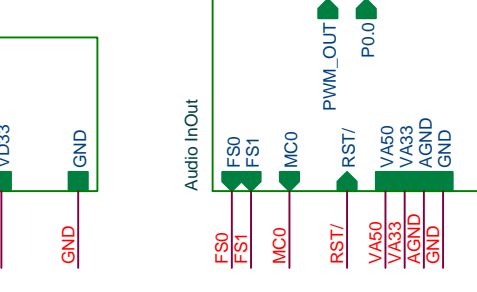
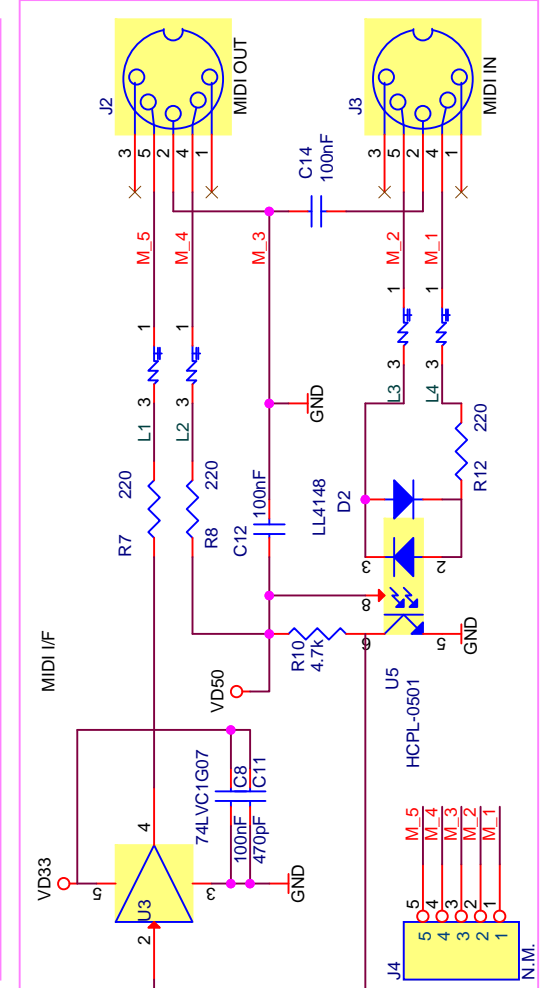
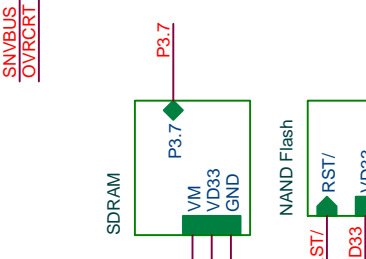
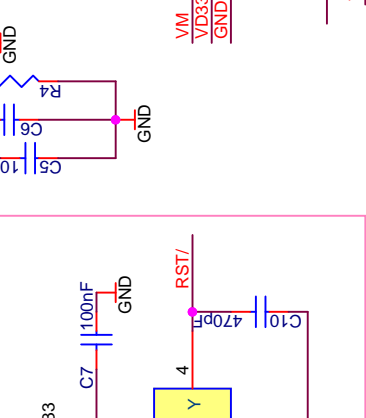
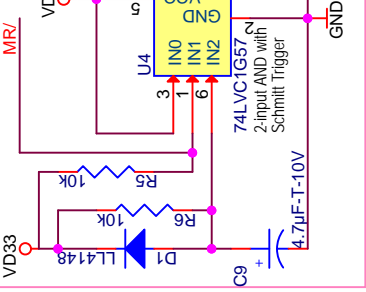
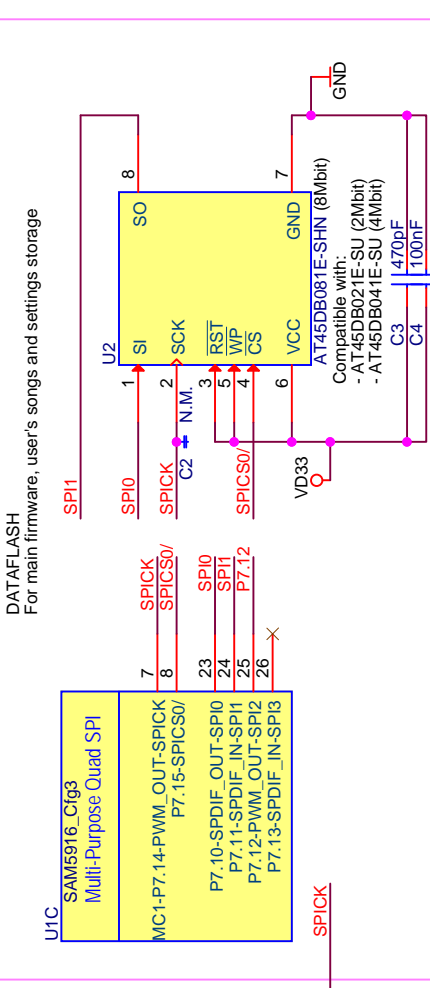
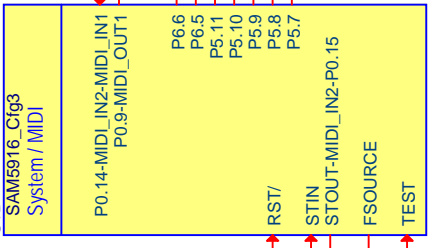
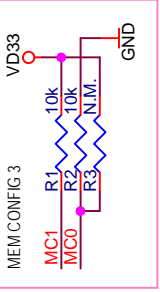

DREAM S.A.S. CONFIDENTIAL DATA

Title SAM5916 - PIANO BOARD - Top

Size A4 Document Number 5916PIA2-DK.DSN

Date: Monday, August 31, 2020 Sheet 1 of 8

Rev 0.2

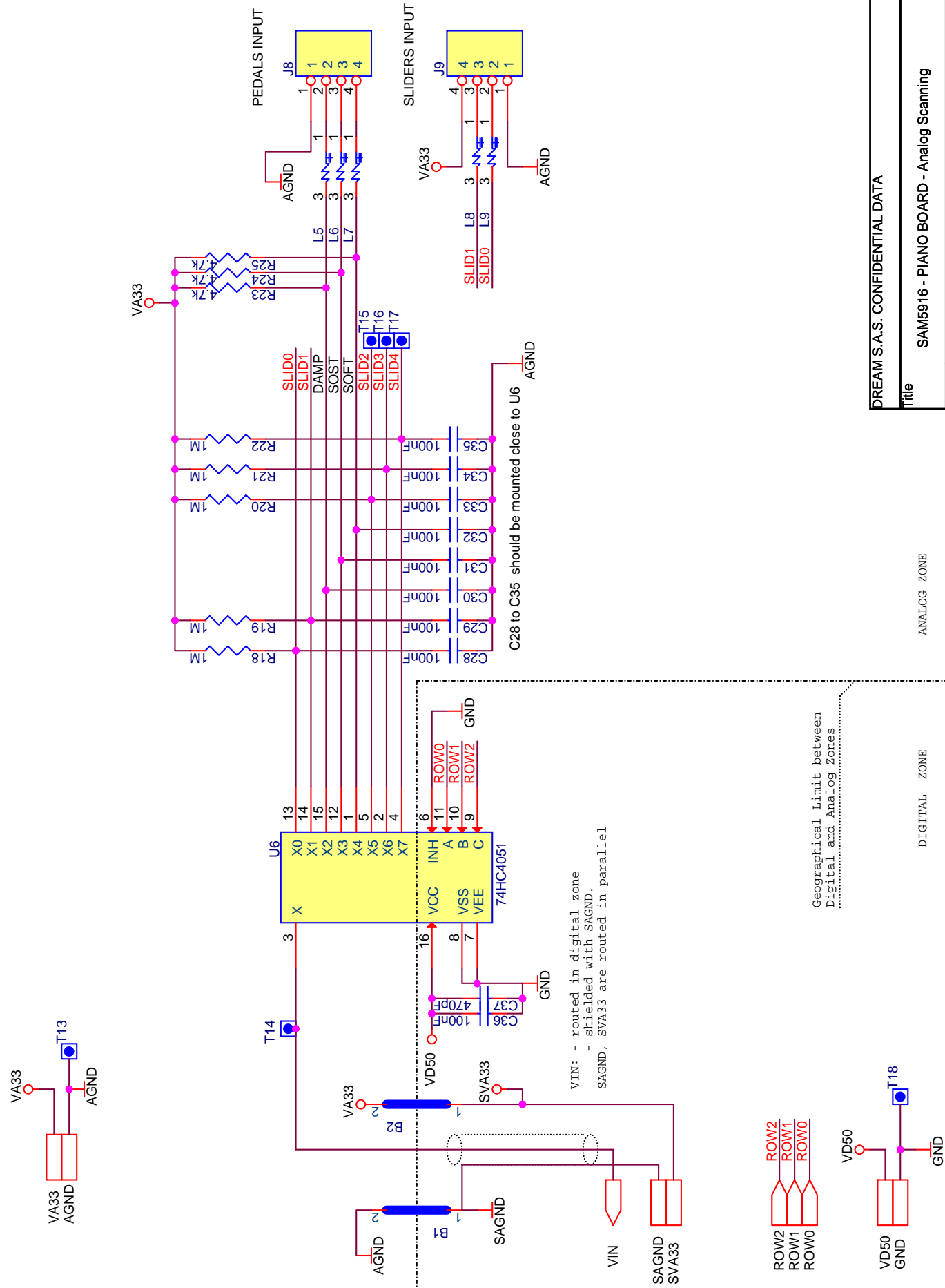

VIN: - routed in digital zone  
 - shielded with SAGND.  
 SAGND, SVA33 are routed in parallel

C28 to C35 should be mounted close to U6

Geographical Limit between Digital and Analog Zones

DREAM S.A.S. CONFIDENTIAL DATA	
Title	SAM5916 - PIANO BOARD - Analog Scanning
Size	Document Number 5916PIA2-DK.DSN
Rev	0.2
Date:	Monday, August 31, 2020
Sheet	2 of 8

ANALOG ZONE

DIGITAL ZONE

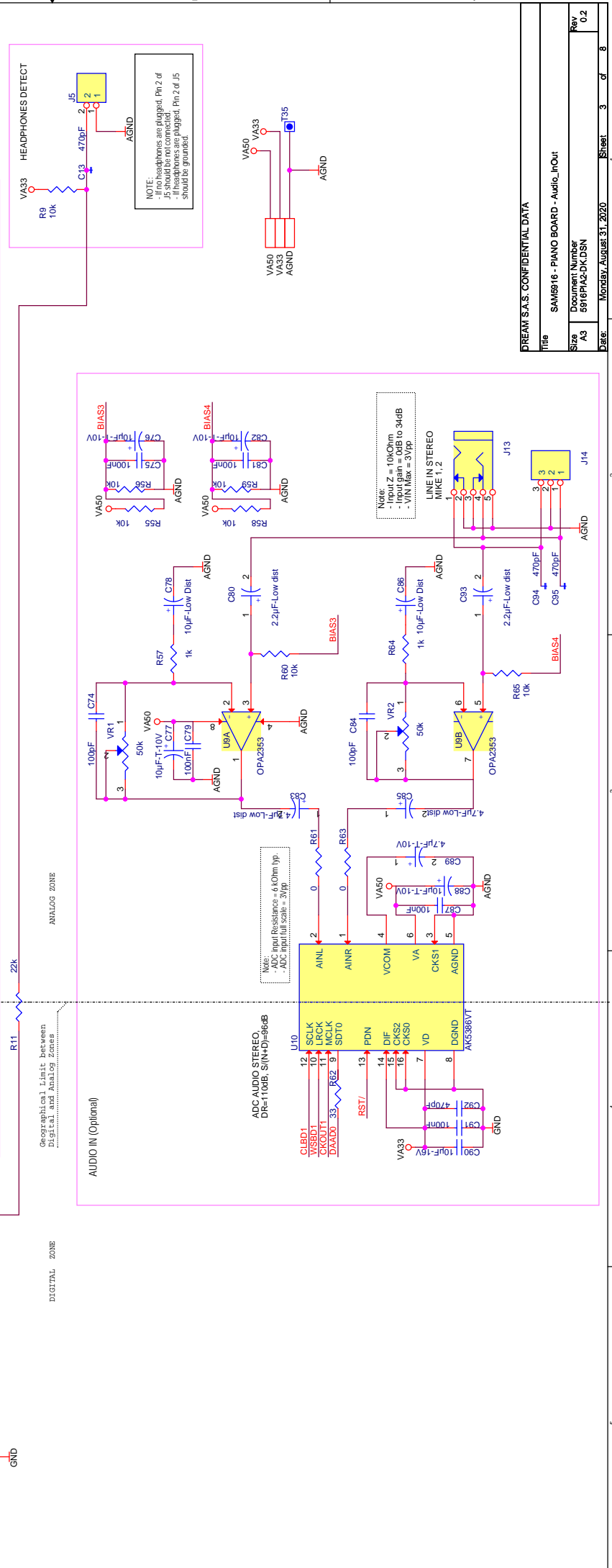
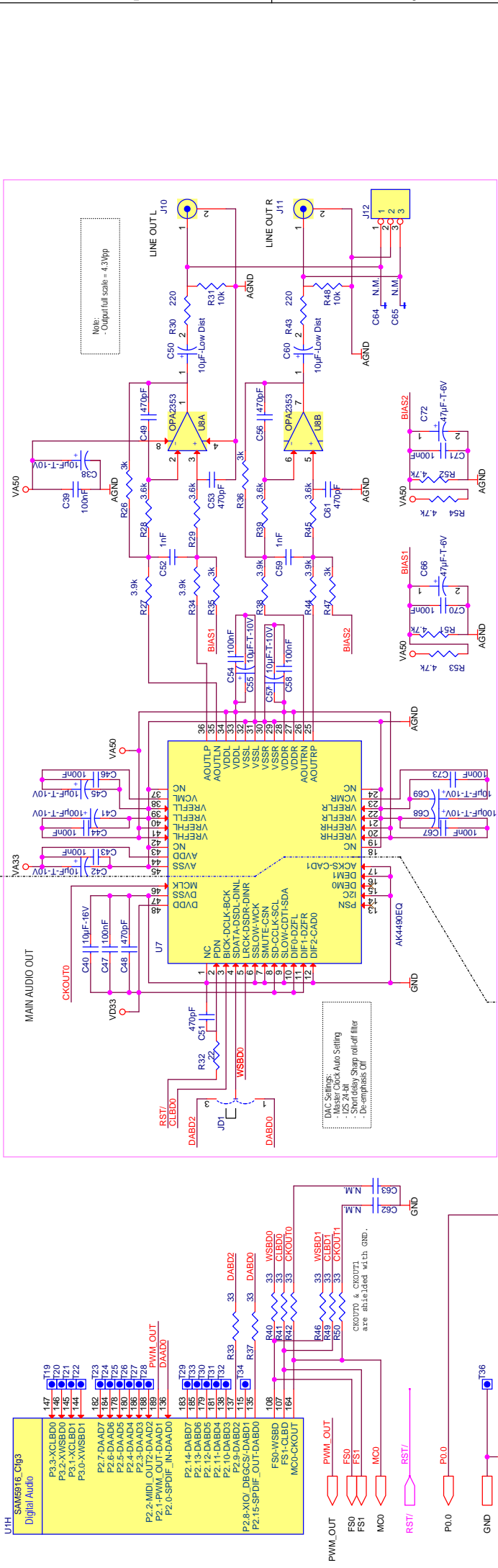





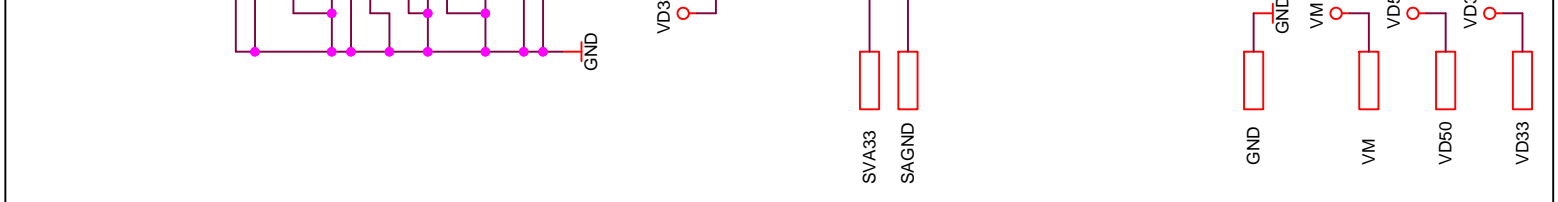
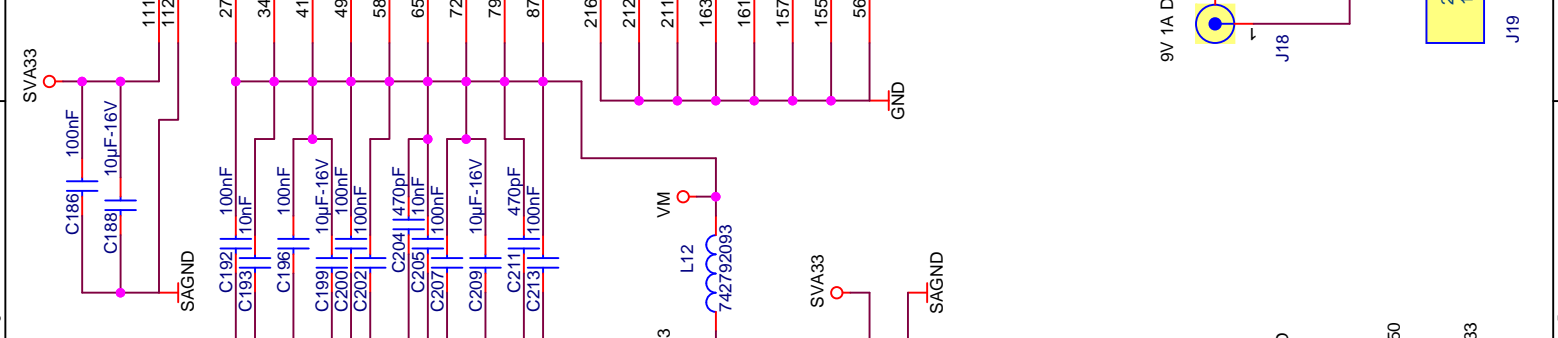
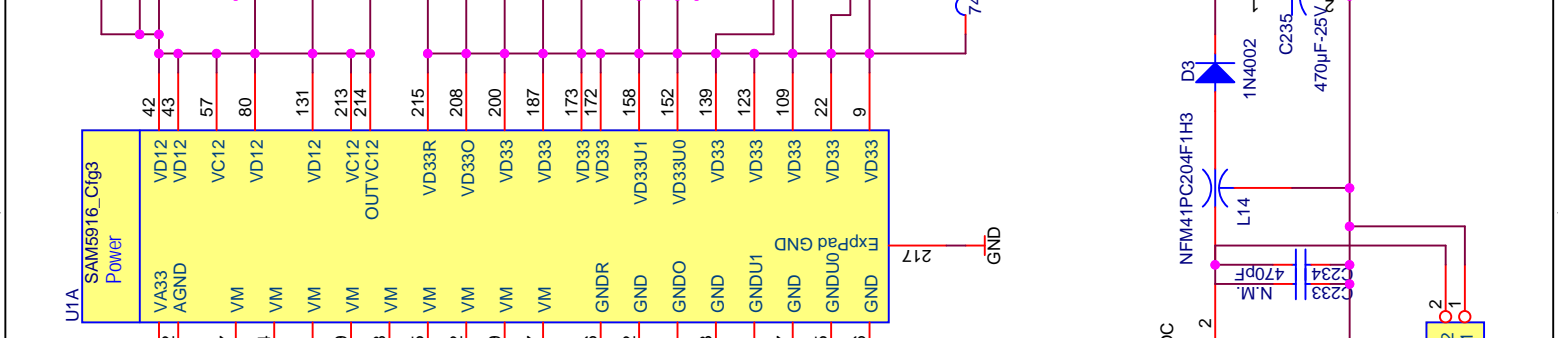
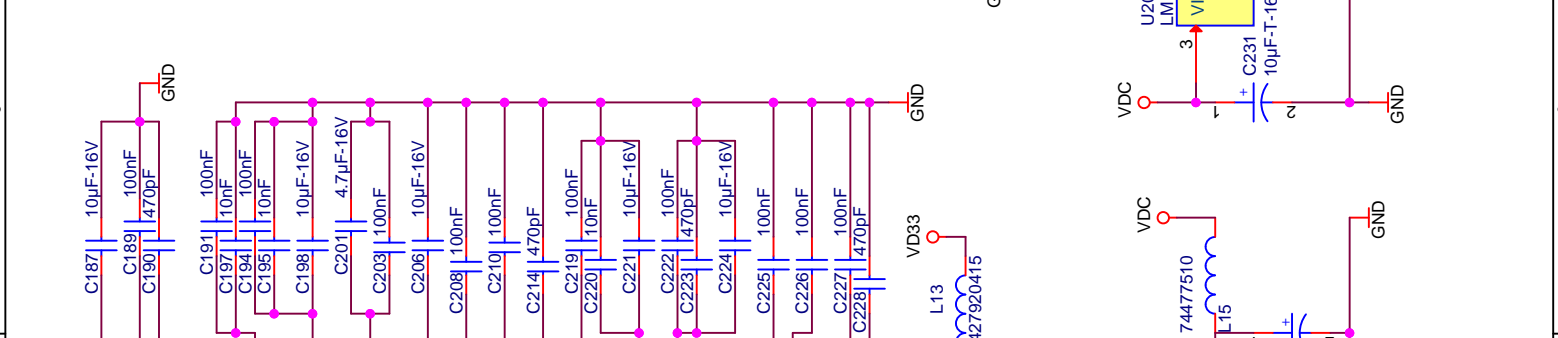
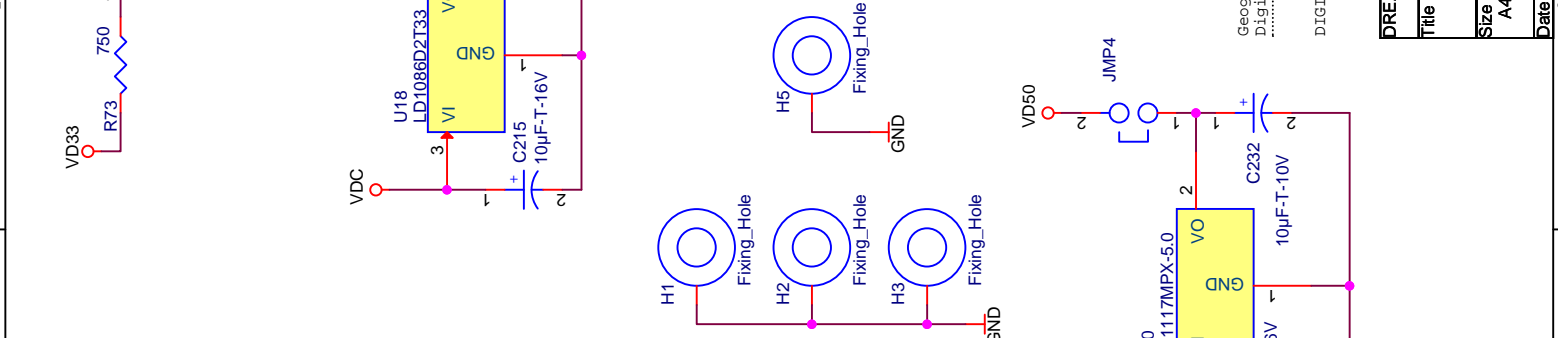
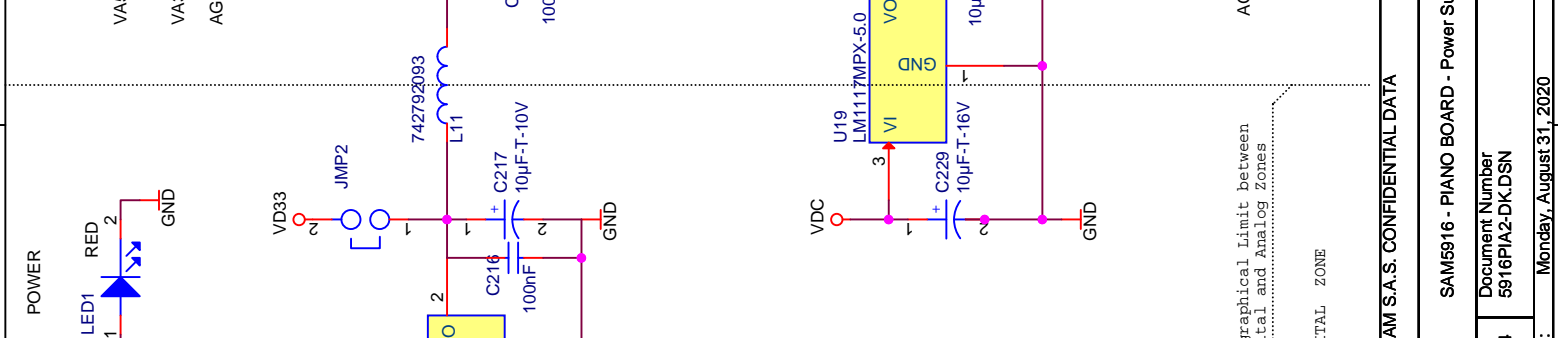
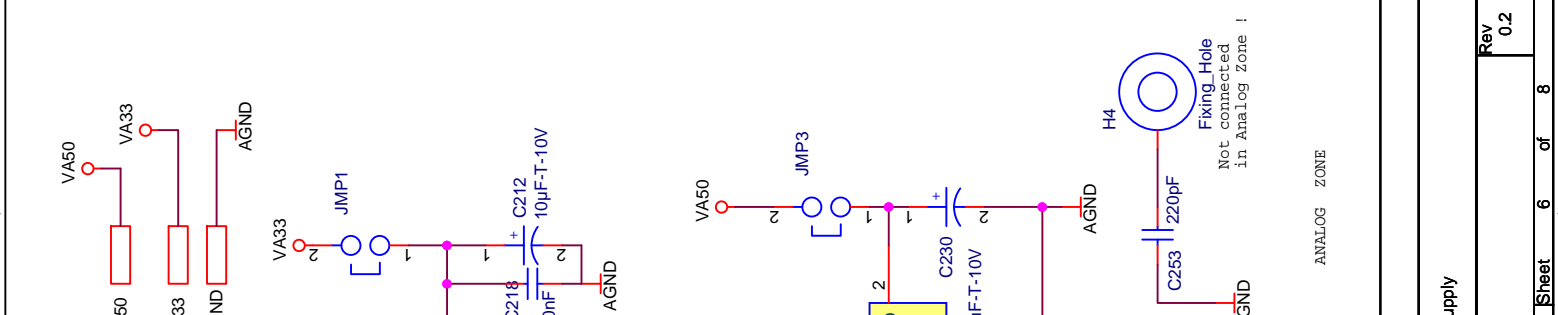
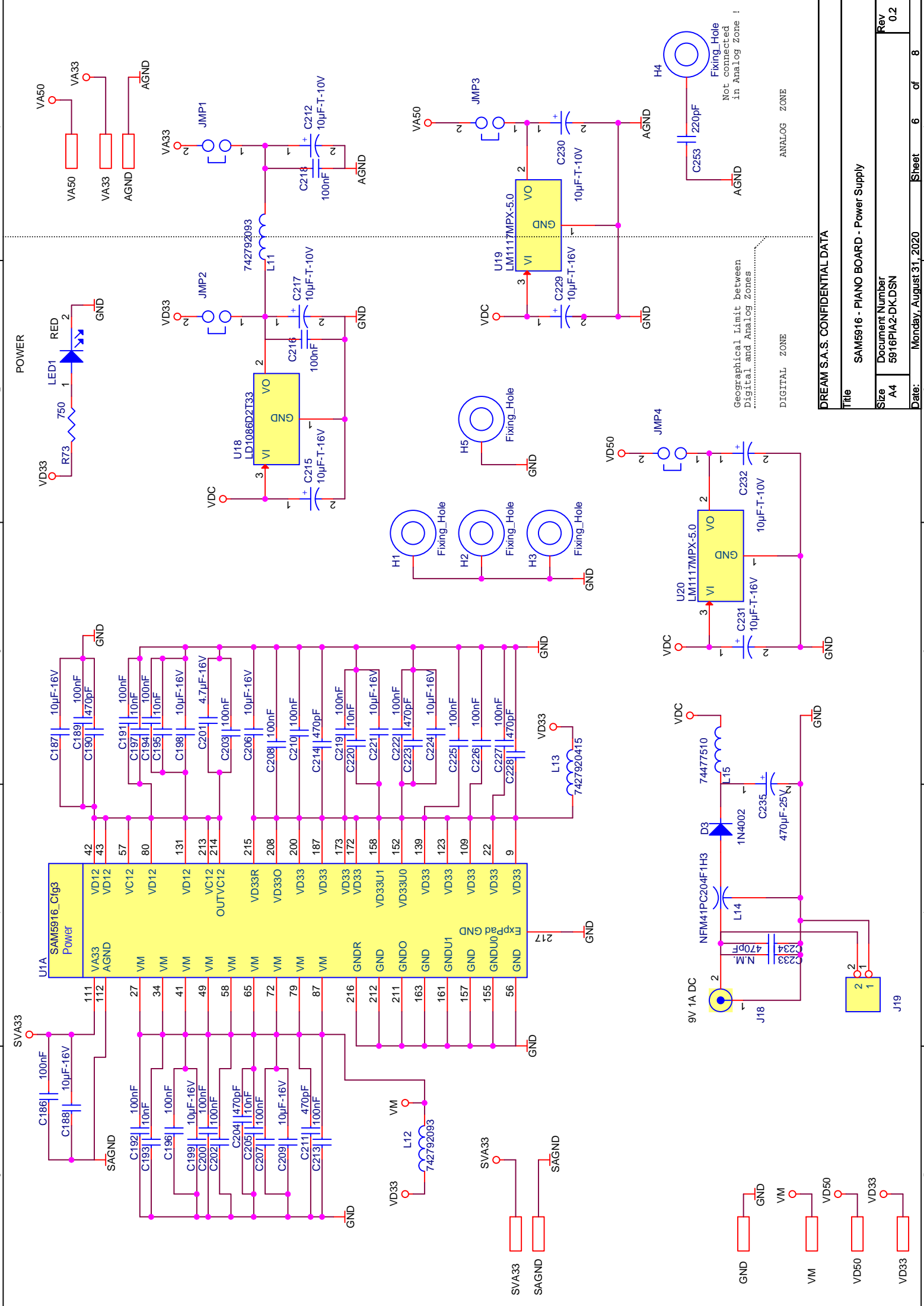



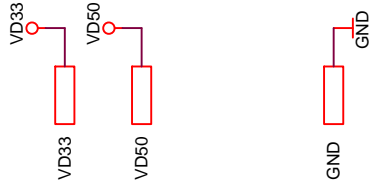
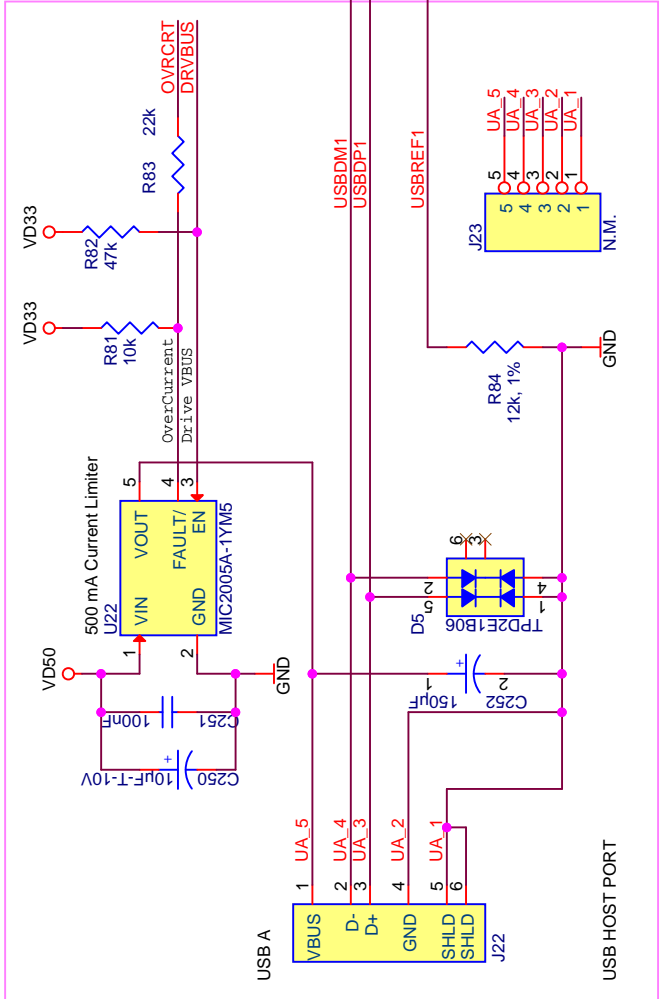
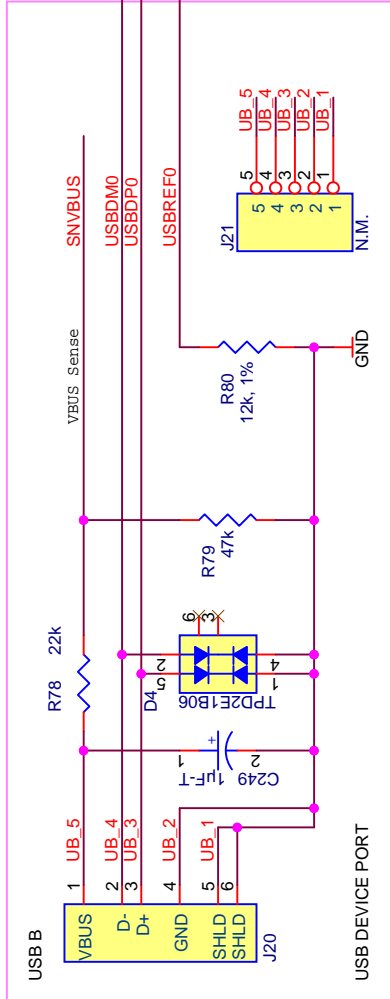
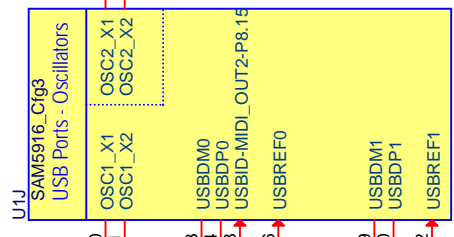
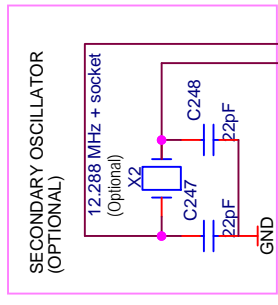
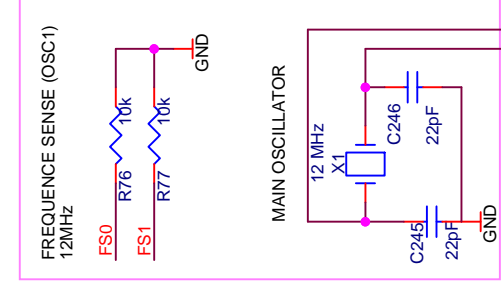
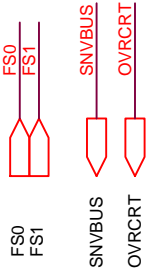

DREAM S.A.S. CONFIDENTIAL DATA

File: SAMS916 - PIANO BOARD - USB Ports

Size: Document Number 5916PIA2-DK.DSN

Date: Monday, August 31, 2020

Sheet 8 of 8

Rev 0.2



## Dream Contact

[info@dream.fr](mailto:info@dream.fr)

## Website

<http://www.dream.fr>

*This publication neither states nor implies any warranty of any kind, including, but not limited to, implied warrants of merchantability or fitness for a particular application. Dream assumes no responsibility for the use of any circuitry. No circuit patent licenses are implied. The information in this publication is believed to be accurate in all respects at the time of publication but is subject to change without notice. Dream assumes no responsibility for errors and omissions, and disclaims responsibility for any consequences resulting from the information included herein.*